



Cashflow SCXX04/XX07

SPARE PARTS GUIDE



©Mars Inc. 2004 Printed in USA.

MEI is a trademark of Mars, Inc. Information is subject to change without notice. MEI has made every effort to ensure that the information in this document is accurate. However, we cannot be held responsible for any errors or omissions.

Version: July 2004

TABLE OF CONTENTS

Main Components.....	Page 3, 4
Acceptor Assembly.....	Page 5, 6
Top of Acceptor Assembly....	Page 7, 8
Lower Acceptor Assembly.....	Page 9, 10
Cashbox Assembly.....	Page 11, 12
Chassis Assembly.....	Page 13, 14
EBDS Specific Control board & Connector	Page 15, 16

Main Components

Ref Num	Description	Part Number
1	Chassis	252018094P1
2	Acceptor Module SC66 GEN.2 SC83	252014091P1 252011001P1
3	Cashbox (Bulk 12)	50043690P12
4	Universal Bill Entry Guide, Black SC66 (Bulk 24) SC83 (Bulk 24)	252067014 252065015
5	Platform Bill Entry Guide SC66 (Bulk 24) SC83 (Bulk 24)	252063016 252060065
6	Lit Coin Resistant Bill Entry Guide SC66 (Bulk 24)	252065054
7	Coin Resistant Bill Entry Guide SC66 (Bulk 24) SC83 (Pak 1)	252063055 252065059P1

Main Components

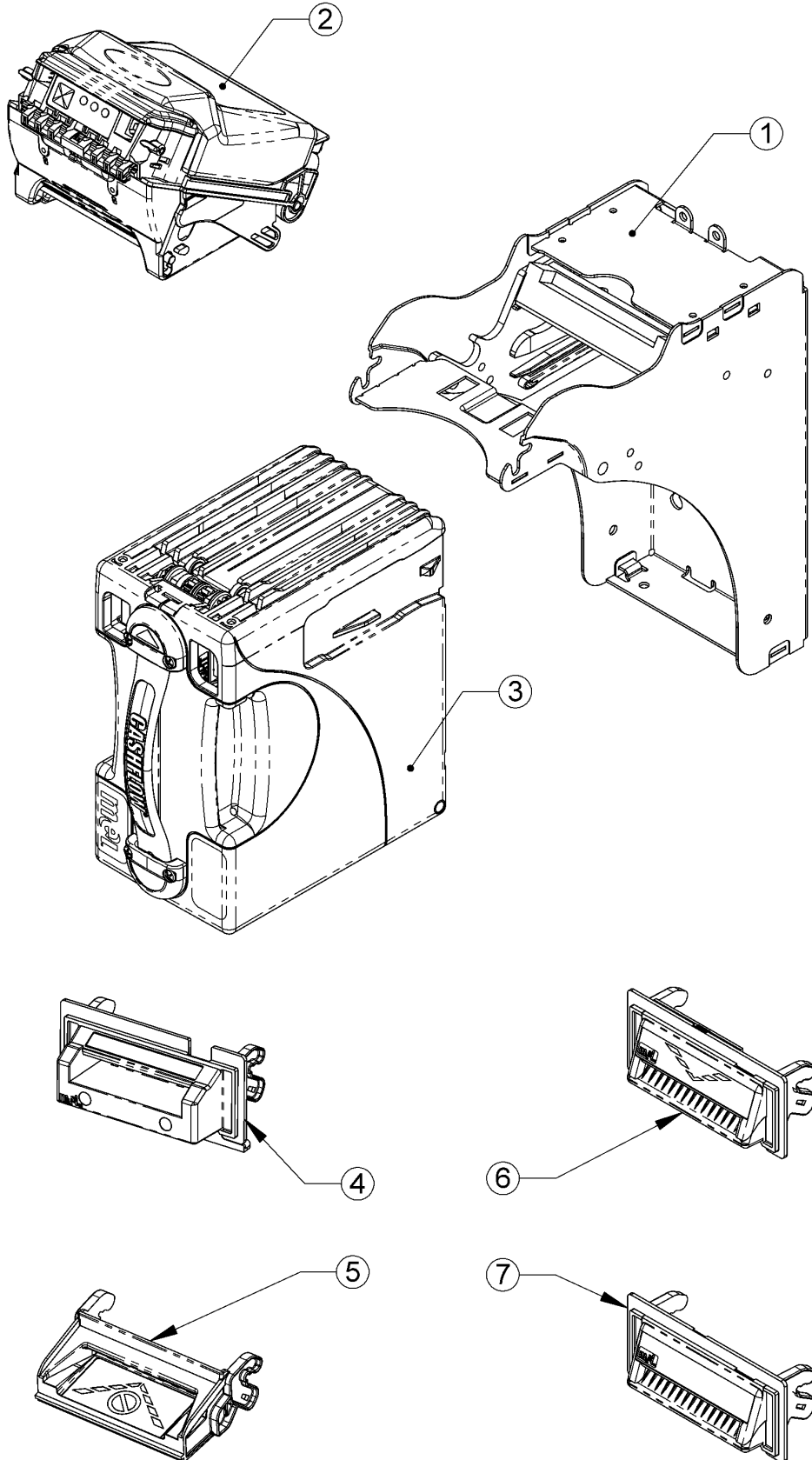

Acceptor Assembly

Ref Num	Description	Part Number
1	Acceptor Module Gen.1 Acceptor Module Gen.2	See Pg. 3
	Yellow Latch Cover Assembly (pak10) <ul style="list-style-type: none"> • Yellow Latch Cover • Springs • Label 	252011040P
2	Yellow Latch Cover- No label or springs (bulk 10)	252020101P
3	Springs, Acceptor Latch (bulk 100)	252043035P
4	MMI Switch (bulk 5)	252086004P
N/S	Label, latch cover (bulk 50)	252054014P
N/S	CF SC PROM, Blank, (Bulk 32)	252060060P

Acceptor Assembly

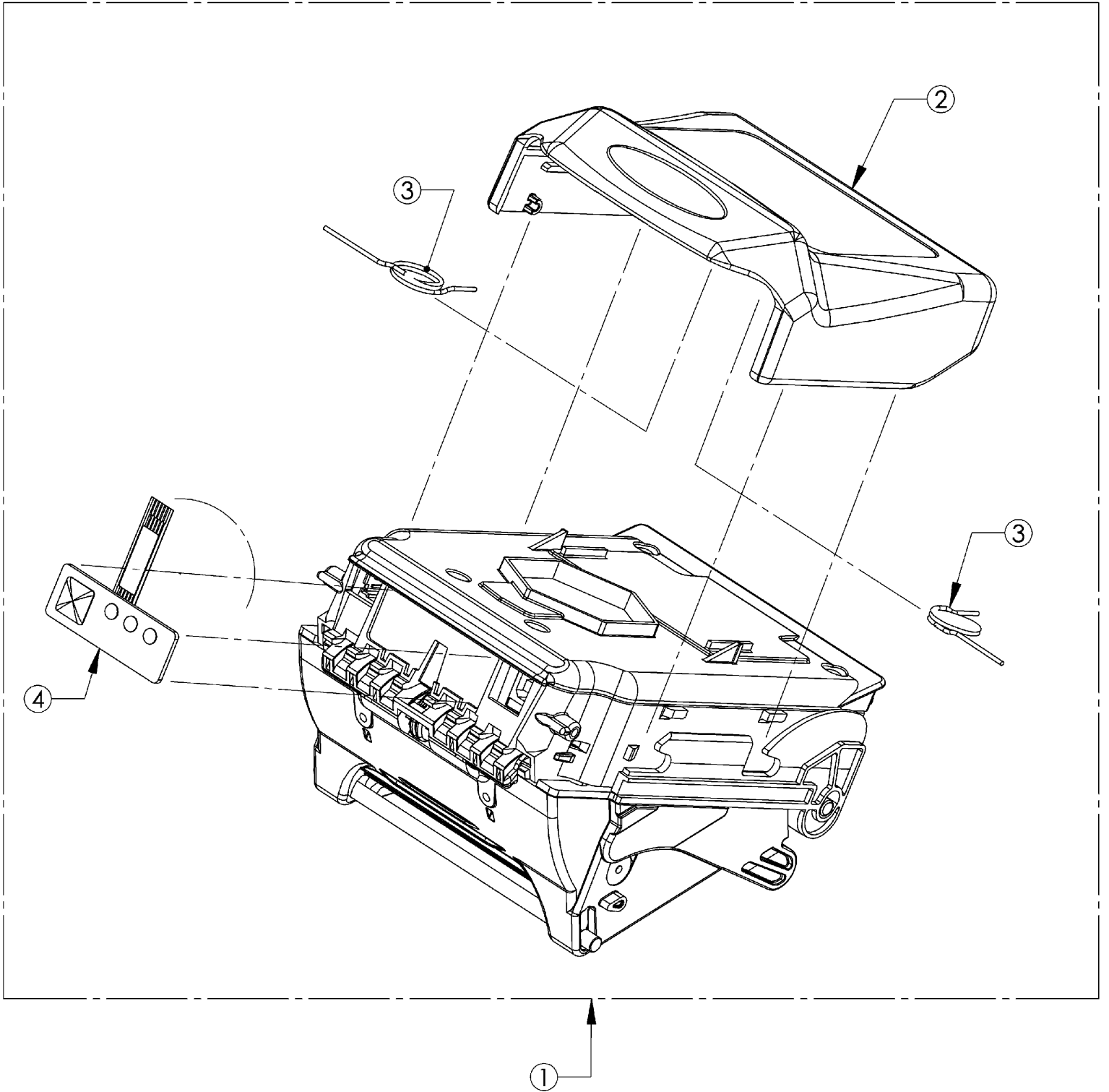

SC66/83 Upper Acceptor Assembly

Ref Num	Description	Part Number
1	Upper Hsg/Drive 4 bulk 1 SC66 SC83	252012097P1 252010098P1
2	Pinch roller, bulk 100	250029011P
3	Pinch roller guide front, bulk 100	252024109P
4	Pinch roller guide rear, bulk 100	252029110P
5	Pinch, bearing 6MM (derlin) bulk 100	252021234P
6	Plunger, Pinch sphere bulk 100	252027111P
7	Spring, Pinch Roller bulk 100	252044026P
8	Gasket, nip roller HSG, front bulk 100	252026245P
17	Srew, 4-20x12.7L,PH,Pozi bulk 100	252041036P
22	Assy, Receiver Housing bulk 5	252010037P
25	Cover, control PCB bulk5	252026005P
31	Screw, 4-20x7.9L,PH, pozi bulk 100	252045017P
34	SC66 Gen. 1 control brd. bulk 1 SC66 Gen. 2 control brd. bulk 1 SC83 control brd. bulk 1	111558387P 111550440P1 111550401P1
35	SC66 optics brd. (Gen. 2) bulk 1 SC83 optics brd. bulk 1	111558441P1 111552400P1

SC66/83 Upper Acceptor Assembly

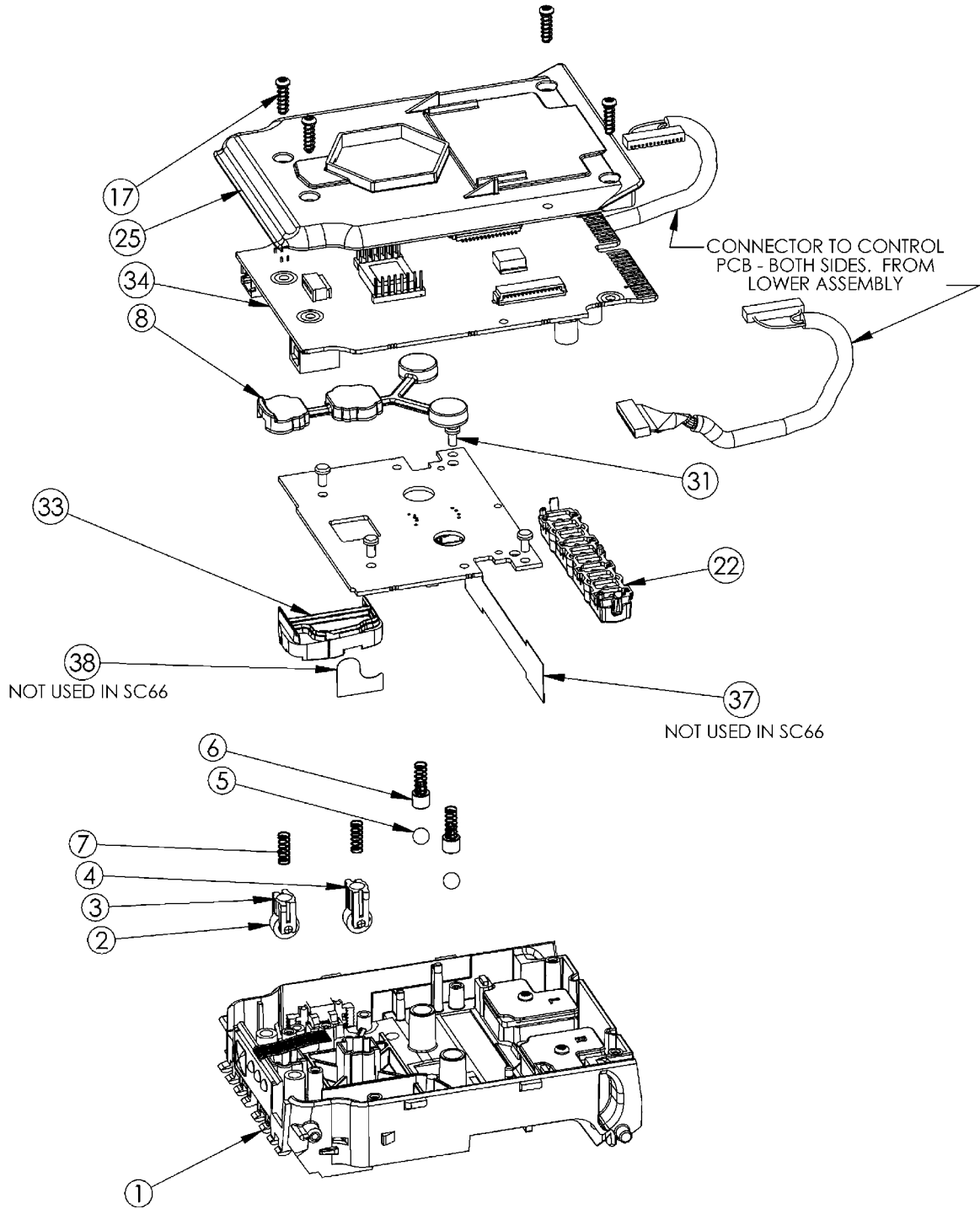

Lower Acceptor Assembly

Ref Num	Description	Part Number
1	Acceptor Drive Assembly SC66 SC83	252010093P1 252017003P1
2	SC66 led brd. (GEN.2) SC83 led bed.	111557438P1 111558402P1
3	Reflector Light Bar Housing (bulk 5)	252010037P
4	Control board Harness (bulk 2)	252074012P
5	Lower Housing	252024160
6	Screws (bulk 4)	252045017P

Lower Acceptor Assembly

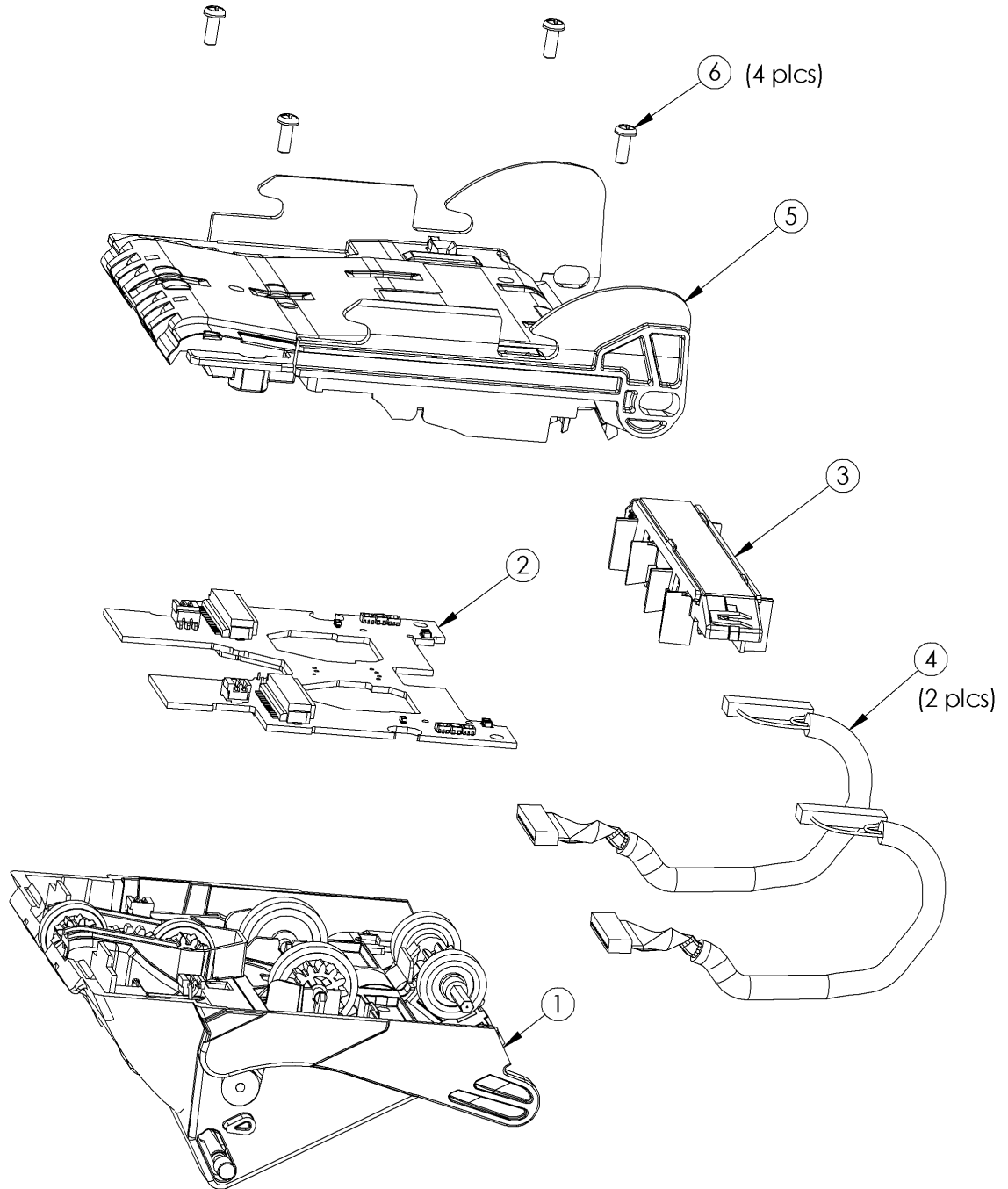

Cashbox Assembly

Ref Num	Description	Part Number
1	Cashbox Handle Kit (bulk 1)	252062003P
2	Stacker Base Assy (bulk 1)	252063077
3	Side & Door Assembly of Cashbox (bulk 1)	252015004P
4	Aperture Plate Assembly (bulk 5)	252011006P
5	Pressure Plate (pak 20)	252021038P
6	Conical Spring (pak 15)	252035063P
7	Hasp (pak 50)	252035002P

Cashbox Assembly

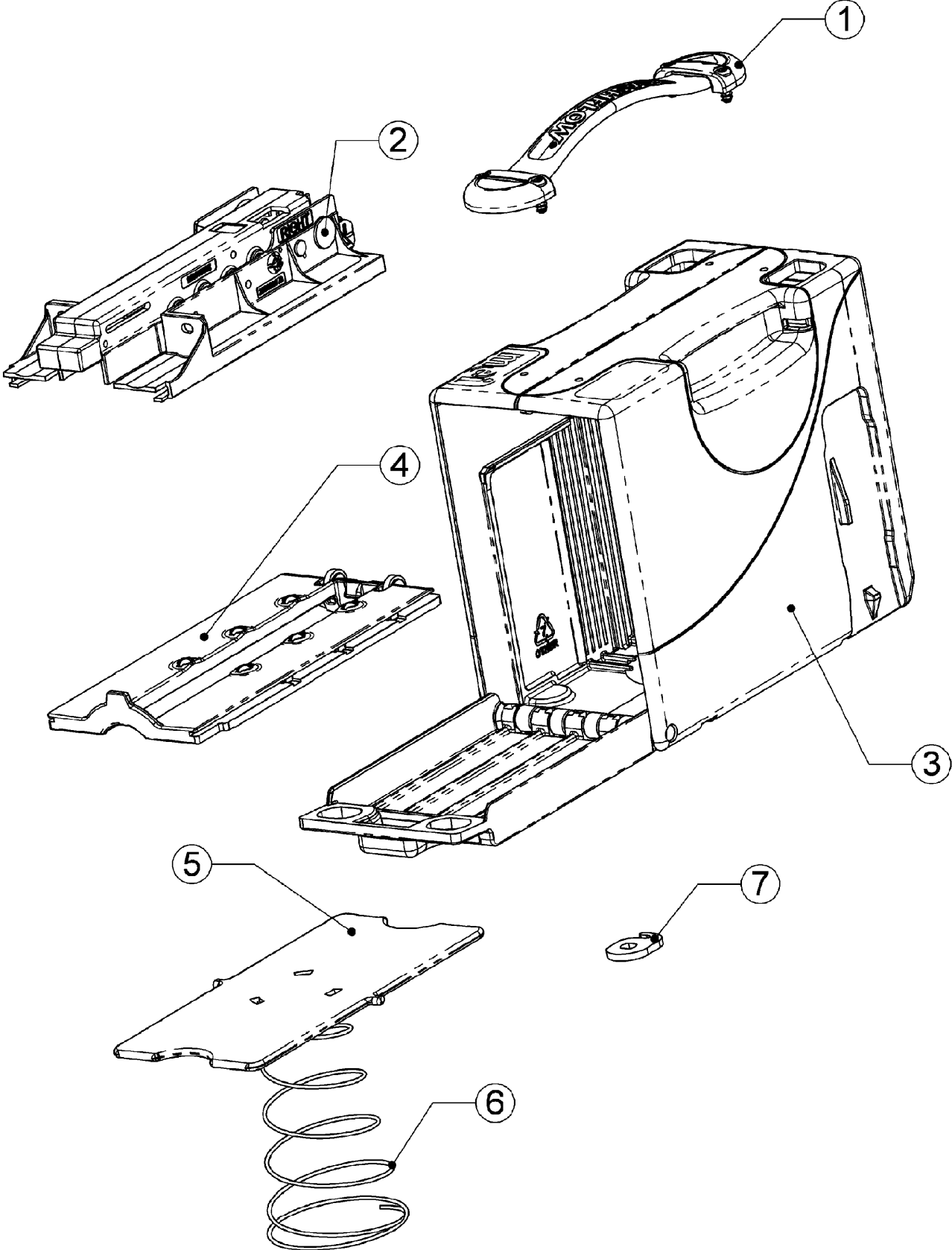

Chassis Assembly

Ref Num	Description	Part Number
1	Assy, Chassis (bulk 1)	252018094P1
2	Clip, Earthing Left (bulk 100)	252031004P
3	Rail Left (bulk 25)	252023250P
4	Rail, Right (bulk 25)	252028249P
5	Guide, Spring (bulk 100)	252021099P
6	Spring, Cassette Reject (bulk 100)	252045012P
7	Hex Nut, Style1, M4X0.7 (bulk 100)	252041019P
8	Screw, 4-20X6L, FH, Pozi (bulk100)	252046020P
9	Spring, Chassis Ext (bulk 100)	252040040P
10	Screw, 4-20X13L, FH, Pozi (bulk 100)	252043030P
11*	Sleeve, Cassette Latch (bulk 50)	252024268P

Chassis Assembly

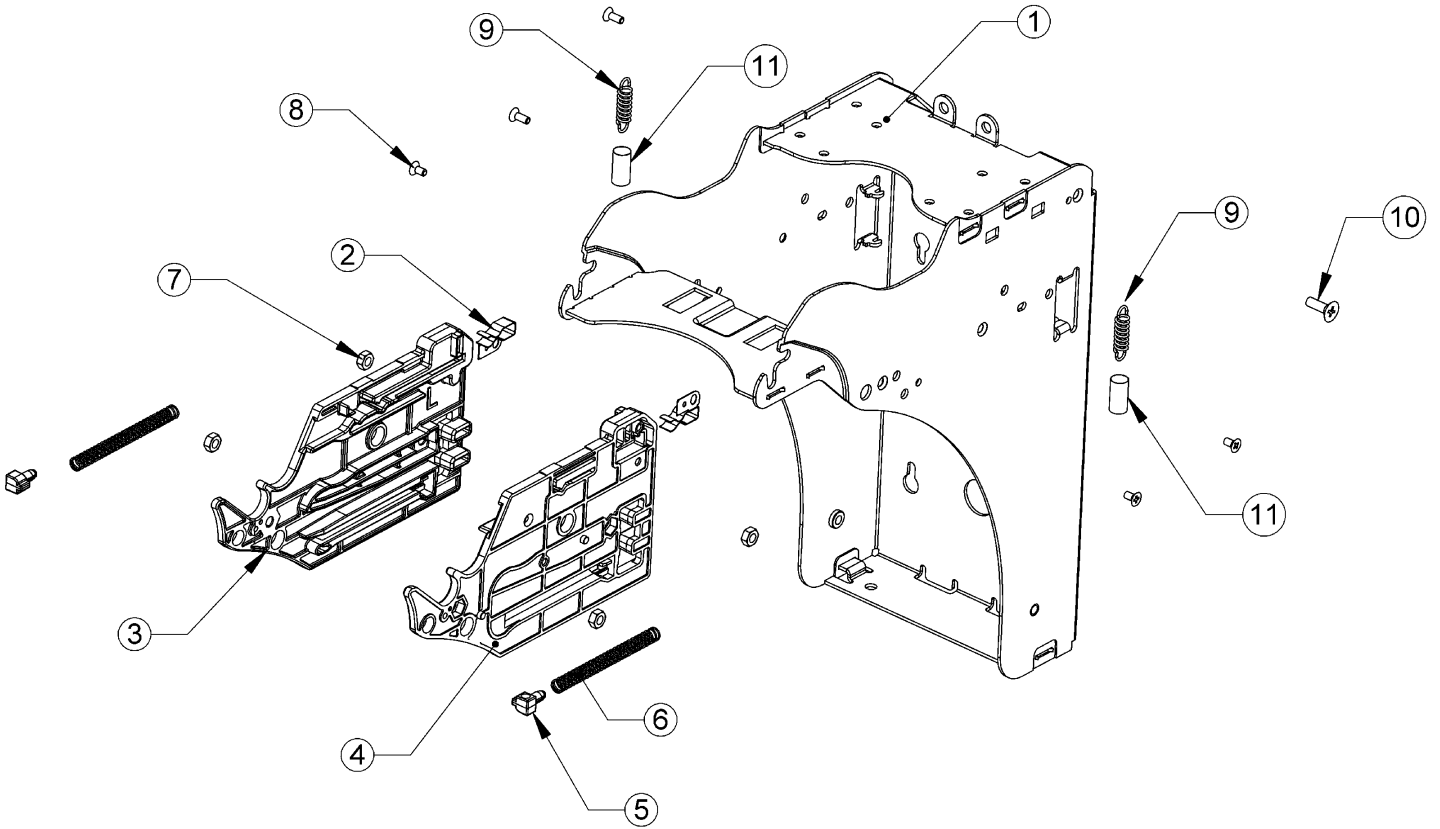

EBDS Specific Interface Board & Connector

Ref Num	Description	Part Number
1	EBDS Specific Interface Board Gen.1 EBDS Specific Interface Board Gen.2 • Switch, Cassette Present (Bulk 50)	252018055P 252026090P1 214791027P
2	SCXX04 Main Harness SCXX04 Main Harness w/ Ext. Inhibit	252077024 252067075
2	SCXX07 Main Harness SCXX07 Main Harness w/ Ext. Inhibit	252078037 252065076
N/S	• External Inhibit Pigtail (bulk 1)	252065071
3	Mounting Plate, edge card connector (bulk 25)	252030030P
4	Screws (bulk100)	252041031P
5	Screws, control board (bulk 100)	252041036P

EBDS Specific Control Board & Connector

