

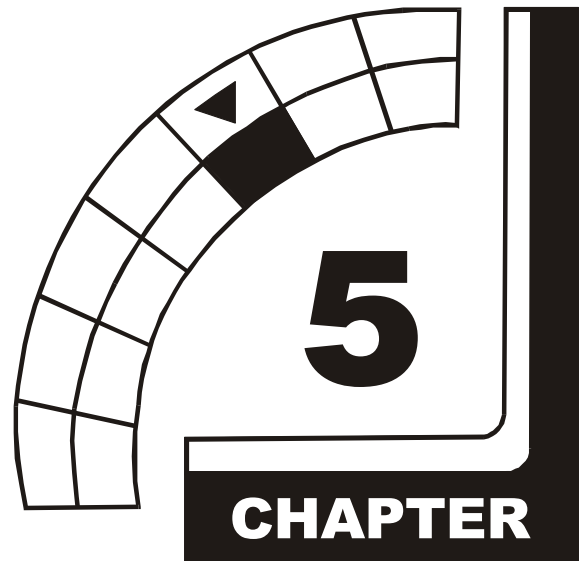



OFFROAD

THE THUNDER™



SERVICING

	NOTICE: The term VGM refers to the video game machine.
	NOTICE: Avoid damage to electronics! Turn off VGM power before servicing circuit boards or any electronic assembly. Never “hot plug” circuit boards.
	CAUTION: Static electricity builds up on your body. This static can damage or destroy sensitive circuits. <i>Before</i> touching or handling electronics, discharge static electricity by touching the power supply chassis.

DISASSEMBLY & REASSEMBLY

This chapter includes summarized procedures for disassembling and reassembling VGM components. Only qualified service personnel should repair VGM equipment. The following product guidelines apply to all video game operators and service personnel. Notes, cautions and warnings appear throughout this manual where they apply. Study the *Safety* pages before beginning service.

- **Arcade Computer**

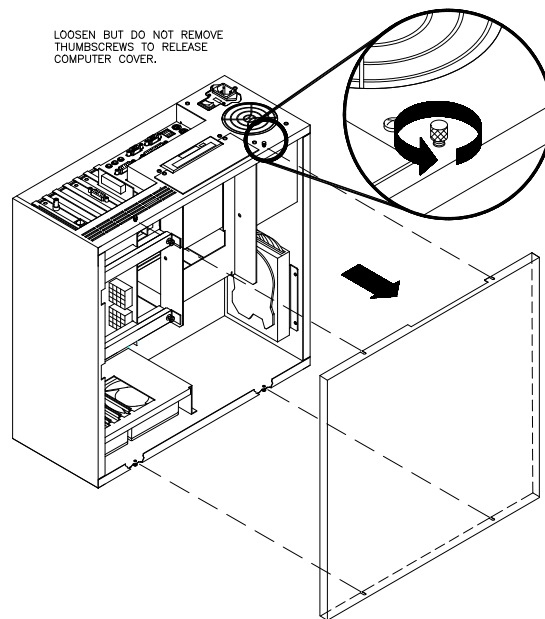

Switch off power to the VGM. Open and remove the rear door. The Arcade Computer is behind this door. To expose Arcade Computer circuitry, loosen four metal thumbscrews. Don't remove the screws. These screws reside at the top and bottom corners of the case. Slide off the back of the computer. For most computer service, you must also separate the Player Panel Cabinet and Monitor Cabinet.



- **Audio Amplifier Board**

Switch off power to the VGM. Unlock and raise the top door of the Player Panel Cabinet. Note the orientation of the connector and other cables. Extract the harnesses from the board connectors. Remove mounting screws and washers from the Audio Board. Lift the board off its mounting posts. Handle the board by a heatsink. If you aren't reinstalling the board, store it in an anti-static bag and protective container.

- **Battery**

	<p>CAUTION: If you install the battery incorrectly, it may explode! Avoid direct shorts across the terminals or from terminals to ground. These batteries are designed for very long life. Don't attempt to recharge these batteries!</p>
	<p>CAUTION: Avoid an explosion! Replacement batteries must match the originals in size, voltage rating, and composition. Manufacturer recommended equivalent types are acceptable. Store batteries in a safe place until you've completed repairs. Dispose of used batteries according to manufacturer instructions.</p>

A battery on the CPU Board retains data in memory during power disruptions. This battery is a 3-volt, lithium button cell. Switch off power to the VGM. Separate the Player Panel Cabinet and Monitor Cabinet. Unlock and raise the top door of the Player Panel Cabinet. The Arcade Computer is under this door. Remove the back of the Arcade Computer. The battery resides toward the edge of the

motherboard, near the daughter board sockets. Carefully pry up the battery retaining lever. Then grasp the battery edges and remove the device. Set the battery aside.

Note the “+” marking on one side of the replacement battery. When you install a battery, this “+” marking must face the battery retaining lever. After replacing the battery, set the system clock to the correct date and time. Also enter the Menu System and check or update system adjustments as necessary.

- **Coin Counter**

Meter replacement requires vault removal. Switch off power to the VGM. Unlock and open the coin door and cashbox door. Find the meter behind the bottom of the cashbox door. Remove the cashbox.

Remove two mounting screws at the bottom (front) of the vault assembly. Reach through the cash door. You’ll find two mounting screws at the back of the vault. Remove these. Access the four remaining vault screws from the inside-back of the cabinet. Remove these four screws. Slide the vault out of the cabinet.

Locate the meter wires under the vault. Disconnect wiring at the connector. Remove two mounting screws from the front of the meter. Remove the meter. Assure that the replacement meter has a diode across its terminals. This diode protects driver circuits from the meter’s inductive kick. Install the new meter. Log the new meter count.

- **Coin Mechanism**

Switch off power to the VGM. Unlock the coin door and swing it open. To clean or replace a coin mechanism, unlatch and remove it. After reinstallation, assure that the mechanism seats fully in its bracket. Close and lock the release latch. Then close the door. Enter the Menu System to change the coin mechanism setup. Test known good and bad coins to verify operation.

- **CPU Board**

The CPU Board is part of the Arcade Computer. Switch off power to the VGM. Separate the Player Panel Cabinet and Monitor Cabinet. Unlock and raise the top door of the Player Panel Cabinet. The Arcade Computer is under this door. Find the four metal thumbscrews at the top and bottom corners of the computer case. To expose the CPU Board, loosen, but don’t remove these screws. Slide off the back of the computer. Disconnect the floppy disk power and data cables at the disk drive. Remove the floppy drive mounting bracket. Lift the bracket and floppy drive out of the cabinet. Set these aside for reassembly. Remove the CPU Board power cables at the CPU Board. Remove the circuit board retention bars. Remove the Video card, Network card, and DC Filter board. Disconnect the hard drive power and data cables at the disk drive. Remove CPU Board mounting screws. Lift the circuit board out of the cabinet and set it aside for reassembly. Use anti-static packaging from new parts to store boards that you won’t reinstall.

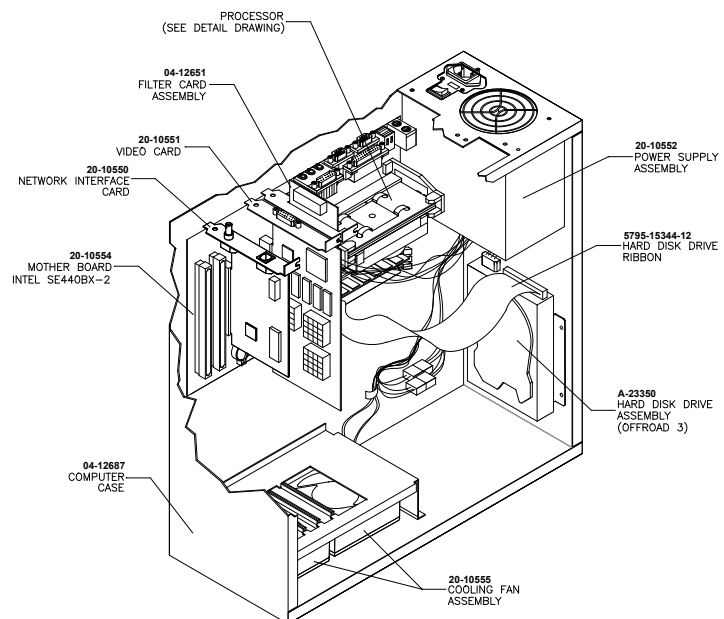

- **Dashboard and Steering Mechanism**

Switch off power to the VGM. Separate the Player Panel Cabinet and Monitor Cabinet. Unlock and raise the top door of the Player Panel Cabinet. Disconnect the wiring harnesses from the dashboard. Support the steering wheel. Remove one screw from each corner of the instrument cluster. Remove the support. Carefully set the dash assembly on your workbench.

Inspect the motor, pulleys, and belt. If the belt is broken or shows signs of wear, replace it. Locate the two nuts on each side of the motor mounting bracket. Loosen all four bracket nuts. Rotate the tension adjustment bolt as necessary. Tighten this bolt until the belt is taut. Then restore correct tension by loosening the bolt one full turn. Tighten the motor bracket nuts.

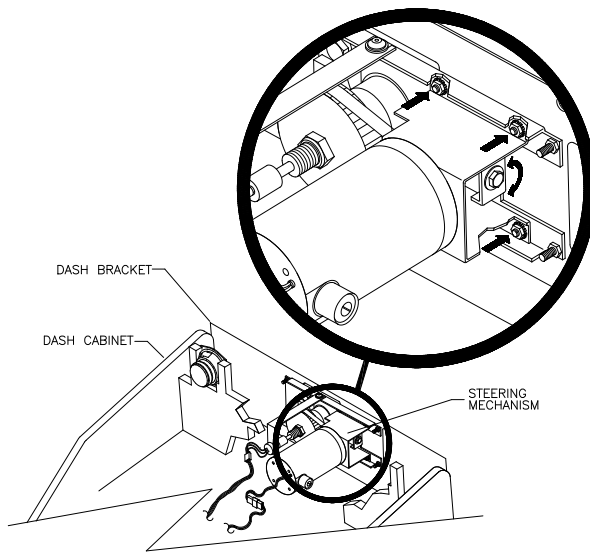

- **DIMMs (Dual In-Line Memory Modules)**

DIMM circuits contain the computer read-write memory for this VGM. Switch off power to the VGM. Separate the Player Panel Cabinet and Monitor Cabinet. Unlock and raise the top door of the Player Panel Cabinet. Remove the back of the Arcade Computer. Unplug the ribbon cable from the floppy drive. Leave the other end of the cable attached to the CPU Board. Unscrew and remove the circuit board retention bars. Remove the floppy drive mounting bracket. Remove the floppy drive. Note DIMM positions. Press out on the locking retainer on each side of the DIMM. The DIMM should partially or completely pop out of its socket. Lift the DIMM from its socket. Handle the DIMM only by its edges.

To reinstall memory circuits, orient the DIMM over its socket. Make sure that you've positioned the keying holes and notch properly. Push the DIMM board into its socket, so that the board snaps into place under the locking retainer on each side of the socket. Be sure that the retainers mate tightly with DIMM board notches. *Don't attempt to force a DIMM into its socket.*

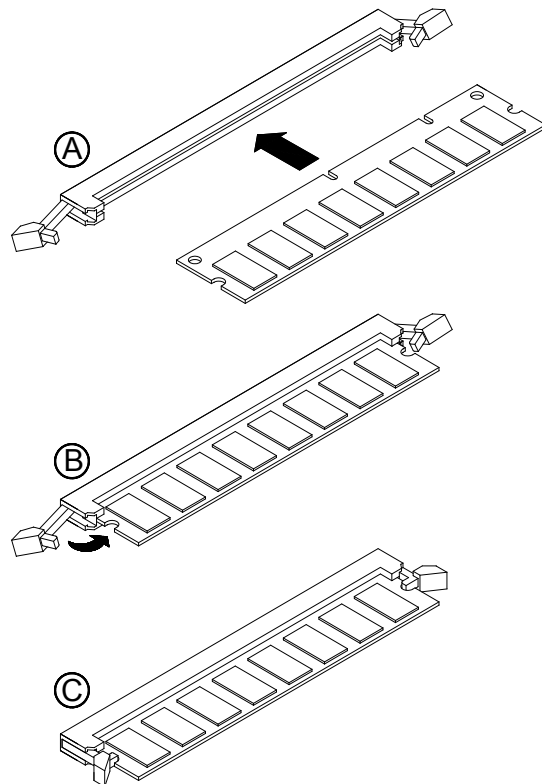

- **Dollar Bill Validator**

(Use MARS AE2451-U3E, UL-recognized currency changer)

You can install dollar bill validators in VGMs manufactured with the additional wiring connector. Other currency acceptors will also work with this connector.

Switch off power to the VGM and unplug the AC line cord. Unlock the coin door and swing it open. Read the coin door label for additional information.

Remove nuts, spacers, and the cover plate from the door. Before mounting the validator, change switch settings or make adjustments. If the manufacturer supplied an adapter plate, place it over the door cutout. Install spacers on threaded studs. Then align the validator mounting holes with the studs. Seat the validator in the door opening. Install the nuts and tighten them.

Attach the ground wire (green with yellow stripe) lug to the door ground stud. The stud is beside the hinge. Mate the wiring harnesses and press them together to fully seat connectors. Route wires away from the door edges and hinge. Inspect the bill chute for proper alignment. Set the dollar bill validator to produce 50ms output pulse widths, 1 pulse per dollar. This setting avoids counting errors. To remove a validator for service or replacement, reverse these steps.

Plug in the line cord and turn on the VGM. From the Menu System, change the mechanism setup and pricing. Then test known good and bad bills to verify proper operation. Close and lock the coin door.

- **Fans**

The Arcade Computer incorporates several fans. Two fans reside at the bottom of the Arcade Computer enclosure. The power supply includes one fan. Inside the microprocessor cartridge is another small fan.

Switch off power to the VGM. Separate the Player Panel Cabinet and Monitor Cabinet. Unlock and raise the top door of the Player Panel Cabinet. Remove the back of the Arcade Computer.

FANS AT THE BOTTOM OF THE ENCLOSURE.

Disconnect the fan's power harness. Remove the fan mounting screws. Note the fan orientation. Each fan has an arrow molded into its plastic case to indicate airflow direction. Slide the fan out of its mounting bracket. Be certain to reinstall the fan in the proper direction to assure airflow over circuitry.

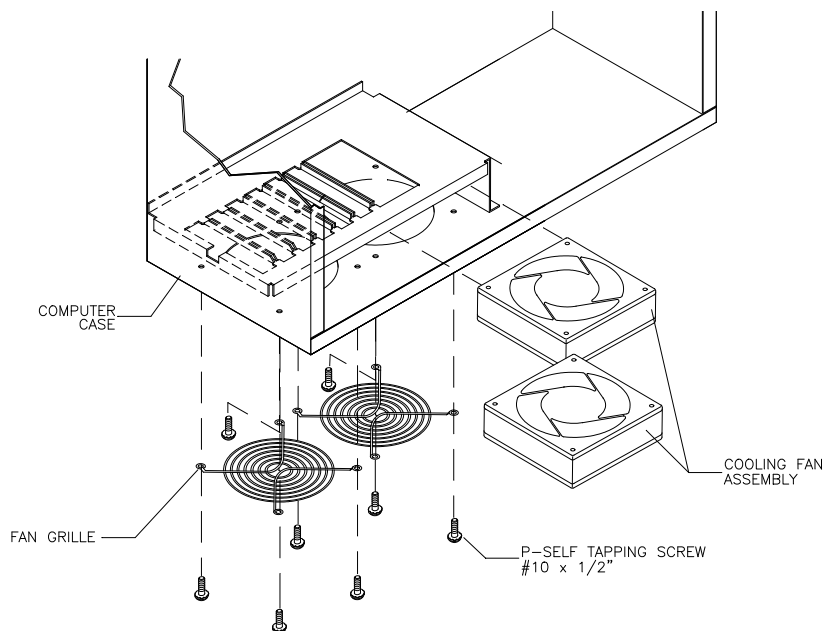

POWER SUPPLY FAN. The power supply contains no user-serviceable parts. Never open the power supply.

MICROPROCESSOR FAN.

Unscrew and remove the circuit board retention bars. Remove the floppy drive mounting bracket. Unplug the ribbon cable from the floppy drive. Remove the floppy drive. Disconnect the fan's power harness. Remove the microprocessor cartridge. Squeeze the plastic end tabs on the fan side of the cartridge. While squeezing, carefully pry the heatsink away from the cartridge. If the fan is bad, replace the entire fan assembly with a new one. Reassemble the cartridge and insert it into the computer. Then reconnect fan power.

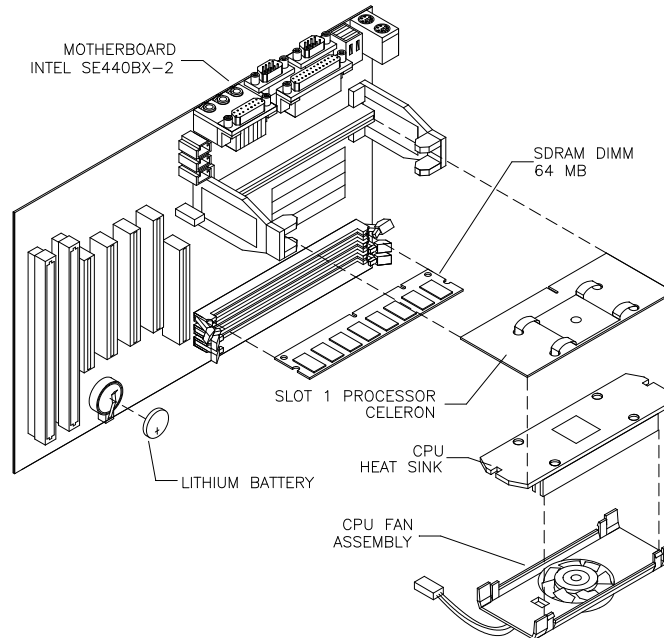

- **Floppy Disk Drive**

Switch off power to the VGM. Separate the Player Panel Cabinet and Monitor Cabinet. Unlock and raise the top door of the Player Panel Cabinet. Remove the back of the Arcade Computer. Disconnect the DC power cable from the floppy drive. Unplug the ribbon cable from the floppy drive. Leave the other end of the cable attached to the CPU Board. Unscrew and remove the circuit board retention bars. Remove the drive bracket mounting hardware. Remove the bracket. Remove the drive mounting screws. Lift the drive off the mounting bracket. Save the mounting screws for reuse in future floppy drive installations. When returning a floppy drive to your distributor, pack it in an anti-static bag.

REINSTALLATION. Mount the floppy drive in its bracket. Install the drive mounting screws. Reinstall the bracket and drive in the Arcade Computer enclosure. Connect the drive's ribbon and power cables.

- **Front Housing**

OPENING THE DOOR AND HOUSING. Switch off power to the VGM. Unlock the front cabinet door and swing it open. Release the latches at the corners under the front housing. Gently pull out on the bottom of the formed front housing and swing it towards the control section. Remove the free end of the prop rod from the retainer at the left side of the monitor shelf. Swing the rod up until it rests in the rod bracket on the lower right side of the front housing. Lower the housing until the prop rod supports the housing's weight.

CLOSING THE DOOR AND HOUSING. Snap the rod into the retainer. Close the housing. Engage latches and snap them shut. Close the front cabinet door

- **Pedal Assembly**

Switch off power to the VGM. Unlock and raise the top door of the Player Panel Cabinet. Disconnect the pedal cable from the wiring harness. Disconnect the safety ground from the pedal frame. Adjust the seat to the maximum rear position. Remove four outer mounting screws from the front perimeter of the pedal plate. Pull the pedal toward the seat until it clears the opening. Then lift it up and away from the cabinet.

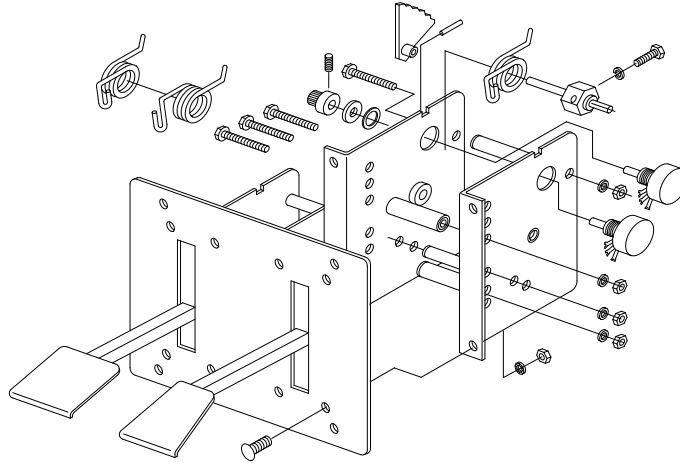

- **Gear Shift**

Switch off power to the VGM. Unlock and raise the top door of the Player Panel Cabinet. Disconnect the two cables from the back of the shifter. At the front of the shifter, remove shift plate mounting screws. Lift the shifter up and out of the player panel.

- **Hard Disk Drive**

	<p>CAUTION: Hard disk drives are very fragile! Handle them with care. Keep disk drives away from magnets, heat and vibration. Don't move a VGM with the power on.</p>
	<p>CAUTION: Don't stack or drop hard disk drives. Use an anti-static bag and an approved shipping container to return the drive to your distributor.</p>

Switch off power to the VGM. Separate the Player Panel Cabinet and Monitor Cabinet. Unlock and raise the top door of the Player Panel Cabinet. Remove the back of the Arcade Computer. Disconnect the DC power cable from the hard drive. Unplug the ribbon cable from the hard drive. Leave the other end of the cable attached to the CPU Board. Remove the drive mounting screws. (Don't remove the drive-mounting bracket.) Lift the drive out of the cabinet. Save the mounting screws for reuse in future hard drive installations. When returning a hard drive to your distributor, pack it in an anti-static bag. Box the drive in approved shipping container 08-8068.

REINSTALLATION. Before mounting the hard drive in its bracket, install the drive mounting screws. To avoid damage during installation, mount the hard drive in the brackets before connecting cables.

After a driver plays one game, the new drive copies data from other linked VGMs. *Important! The data won't copy if players are actively driving. Files transfer only when all VGMs return to Attract Mode.*

- **MagicBus™ Interface Board**

Switch off power to the VGM. Unlock and raise the top door of the Player Panel Cabinet. Extract the harnesses from the board connectors. Remove mounting screws and washers from the MagicBus Board. Remove the MagicBus Board. Lift the board off its mounting posts. During reinstallation, tighten the screws: Start at the board's center and work toward the outer edge. If you aren't reinstalling the board, store it in an anti-static bag and protective container.

- **Marquee**

Switch off power to the VGM. Open the front, monitor cabinet door. To replace the marquee, you must completely remove the front housing from the monitor cabinet. Then you can access the

marquee, and remove it from the bezel. Take the glass and artwork out of the front housing. Clean the glass before reinstalling it. Install the bracket and tighten screws. Replace the front housing on the monitor cabinet. Tighten mounting screws. Don't use excess force.

- **Mars Light Driver Board**



Switch off power to the VGM. Unlock and remove the rear door of the Monitor Cabinet. Note the orientation of the connector and the other cables. Extract the harnesses from the board connectors. Remove mounting screws and washers from the Mars Light Driver Board. Lift the board off its mounting posts. Handle the board by the edges. If you aren't reinstalling the board, store it in an anti-static bag and protective container.

- **Microprocessor**

This VGM's microprocessor is in a postcard-size cartridge that also includes cache RAM. The cartridge is inside the Arcade Computer, near the DIMM sockets. Switch off power to the VGM. Separate the Player Panel Cabinet and Monitor Cabinet. Unlock and raise the top door of the Player Panel Cabinet. Remove the back of the Arcade Computer. Unplug the ribbon cable from the floppy drive. Leave the other end of the cable attached to the CPU Board. Unscrew and remove the circuit board retention bars. Remove the floppy drive mounting bracket. Remove the floppy drive. Disconnect the microprocessor fan power harness. Spread the locking retainers on each side of the microprocessor cartridge. Pull the cartridge out of its socket. Take care not to touch the copper traces on the socket.

To reinstall a microprocessor cartridge, orient the cartridge over its socket. Make sure that you've positioned the keying notch properly. Push the microprocessor cartridge into its socket, so that the cartridge snaps into place under the locking retainer on each side of the socket. Be sure that the retainers mate tightly with cartridge notches. *Don't attempt to force a cartridge into its socket.* Reconnect the microprocessor fan harness.

- **Monitor**

	<p>WARNING: The video monitor is <i>very heavy</i>, with most of the weight toward the front. Solidly support the monitor as you remove from it from the cabinet.</p>
	<p>WARNING: When operating the monitor outside the cabinet, use an isolation transformer. In normal operation, the monitor doesn't require isolation from AC line voltage.</p>

The monitor is very heavy and difficult to balance. Removing the monitor is a two-person task. Don't attempt to remove it by yourself. Switch off power to the VGM. Open the front cabinet door. Disconnect the fluorescent light assembly connector and all monitor cables. Remove the front housing hinge screws and set the housing aside. Remove the monitor bezel and both barrier panels. Remove the four flange nuts securing the monitor's mounting brackets to its mounting panel. Pull the monitor carefully from the cabinet and set in a safe place. The monitor remote adjustment board is behind the front door with the rest of the electronics. Clean the face of the CRT before reinstalling the barrier panels and the monitor bezel.

The monitor is a medium resolution type. Other monitors may look as if you can use them for replacements. Yet the screens of different monitor types curve differently. Only medium resolution monitors fit correctly against the monitor bezel. Other monitor styles won't seal properly, and also won't synchronize.

- **Network Interface Board**

Switch off power to the VGM. Unlock and raise the top door of the Player Panel Cabinet. Remove the back of the Arcade Computer. Note the orientation of the cables. Loosen the header-mounting screw. Disconnect the network cables from the board header connectors. Remove the circuit board retention bars. Remove the board. As you remove the board, handle it only by its edges. Don't touch the copper traces! If you aren't reinstalling the board, store it in an anti-static bag and protective container.

- **Power Filter Board**

Switch off power to the VGM. Unlock and raise the top door of the Player Panel Cabinet. Remove the back of the Arcade Computer. Loosen the header-mounting screw. Disconnect the cables from the board header connector. Remove the circuit board retention bars. Remove the board. As you remove the board, handle it only by its edges. Don't touch the copper traces! Use anti-static bags and protective containers to store the board if you won't reinstall it.

- **Power Supply**

Switch off power to the VGM. Disconnect the line cord. Unlock and raise the top door of the Player Panel Cabinet. Remove the back of the Arcade Computer. Unplug the IEC AC power cord. Inside the Arcade Computer, disconnect DC power cables. These connect to the hard drive, motherboard and other peripherals. Remove four mounting screws from the outside of the Arcade Computer enclosure. Lift the power supply out of the cabinet. Before reinstalling the power supply, check the line voltage switch setting.

- **Speakers**

This VGM has four speakers. One woofer is behind a grille at the back of the driver's seat. Smaller, full range speakers are behind the front of the Player Panel. Below these full-range speakers is one more woofer. Switch off power to the VGM.

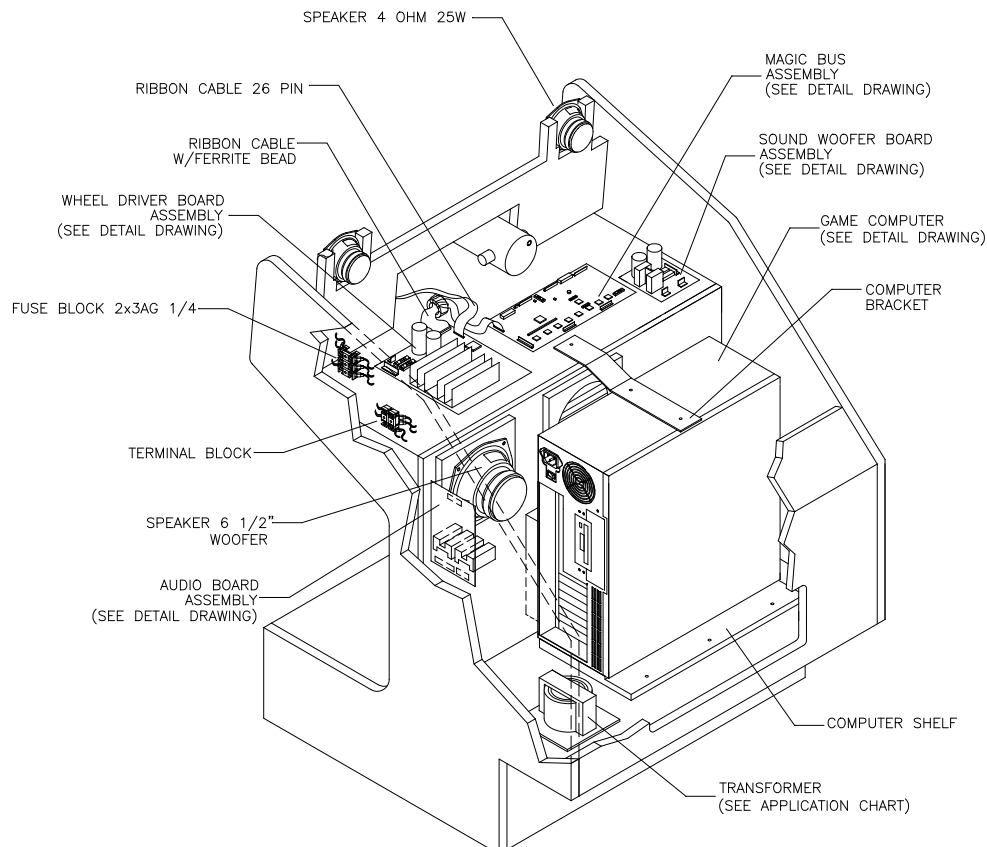

ACCESSING THE SEAT WOOFER. Remove mounting screws and set the speaker grille aside. *Don't use excess force when removing or tightening mounting screws threaded into plastic.* Avoid speaker damage by removing the upper mounting screws first. Replace these top screws last.

ACCESSING A PLAYER PANEL CABINET SPEAKER. Unlock and raise the top door of the Player Panel Cabinet. Remove mounting screws from the rear of the speaker.

SPEAKER REMOVAL. Assure proper polarity by marking each speaker wire (“+” or “Gnd”). Remove the speaker from the enclosure and disconnect the wire lugs.

- **Sub-Woofers Driver Board**

Switch off power to the VGM. Separate the Player Panel Cabinet and Monitor Cabinet. Unlock and raise the top door of the Player Panel Cabinet. Note the orientation of the connector and the other cables. Extract the harnesses from the board connectors. Remove mounting screws and washers from the Sub-Woofers Driver Board. Lift the board off its mounting posts. Handle the board by a heatsink. If you aren't reinstalling the board, store it in an anti-static bag and protective container. The board has two 0.5A, 250-volt fuses. Check these with an ohmmeter. Replace bad fuses only with the identical type.

- **A.C. Power Chassis**

Switch off power to the VGM. Unlock and remove the rear door of the Monitor Cabinet. Note the orientation of the connector and the other cables. Disconnect A.C. Power Chassis harness connectors. Remove mounting hardware from the chassis. Lift the chassis out of the cabinet.

- **Video Board**

Switch off power to the VGM. Separate the Player Panel Cabinet and Monitor Cabinet. Unlock and raise the top door of the Player Panel Cabinet. Remove the back of the Arcade Computer. Loosen the header-mounting screw. Disconnect the video cable from the board header connector. Remove the circuit board retention bars. Remove the board. As you remove the board, handle it only by its edges. Don't touch the copper traces! Use anti-static bags and protective containers to store the board if you won't reinstall it.

- **Viewing Glass**

Switch off power to the game. Open the front cabinet door. To replace the viewing glass, you must completely remove the front housing from the monitor cabinet. Lift the glass out of the front housing. Clean the glass before reinstalling it. Install the bracket and tighten screws. Replace the front housing on the monitor cabinet. Tighten mounting screws. Don't use excess force.



CAUTION: Before you replace the CRT viewing glass, completely remove the front housing assembly from the cabinet. Glass is hazardous to handle with the housing pivoted up on the drop rod.

- **Wheel Driver Board**

Switch off power to the VGM. Separate the Player Panel Cabinet and Monitor Cabinet. Unlock and raise the top door of the Player Panel Cabinet. Note the orientation of the connector and the other cables. Extract the harnesses from the board connectors. Leave the other end of the ribbon cable connected to the MagicBus Board. Remove four mounting screws and washers from the Wheel Driver Board. Lift the board off its mounting posts. Handle the board by the heatsink. If you aren't reinstalling the board, store it in an anti-static bag and protective container.