

ROLLODOWN ACCEPTOR ADJUSTMENT

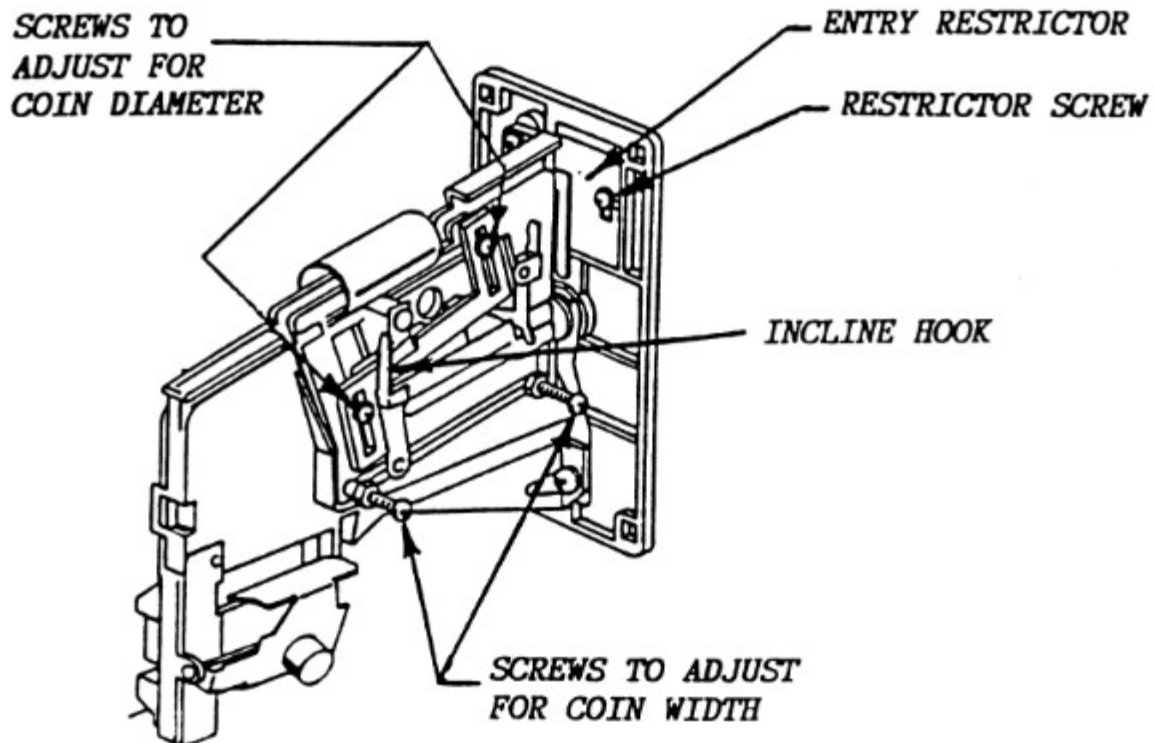

MECH MUST BE MOUNTED UPRIGHT AND VERTICAL WHILE ADJUSTMENT IS BEING MADE.

ADJUSTMENT:

1. LOOSEN "RESTRICTOR SCREW" AND MOVE ENTRY RESTRICTOR UP OR DOWN TO JUST ALLOW COIN TO PASS.
2. LOOSEN "SCREWS TO ADJUST FOR COIN DIAMETER". MOVE "Z" SHAPED BRACKET UP OR DOWN TO JUST ALLOW COIN TO PASS & RE-TIGHTEN.
3. LOOSEN LOCKNUTS ON "SCREWS TO ADJUST FOR COIN WIDTH" AND TURN THESE SCREWS IN OR OUT TO JUST ALLOW THE COIN TO PASS THE INCLINE HOOK. THEN, RE-TIGHTEN LOCKNUTS. (COIN WILL GET CAUGHT ON INCLINE HOOK IF WIDTH SCREWS ARE NOT ADJUSTED PROPERLY.)