

Front Load Bill Validator

MFL Bezel

MFLB-4017

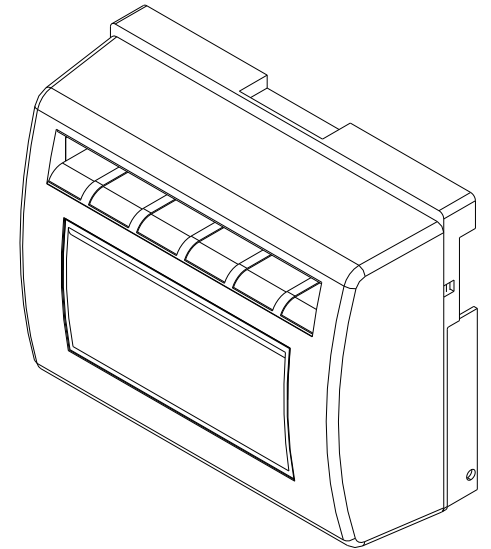

Specifications:

- Runway Lights Bezel
- Handled Bill Width 62-82 mm

Bezel Installation

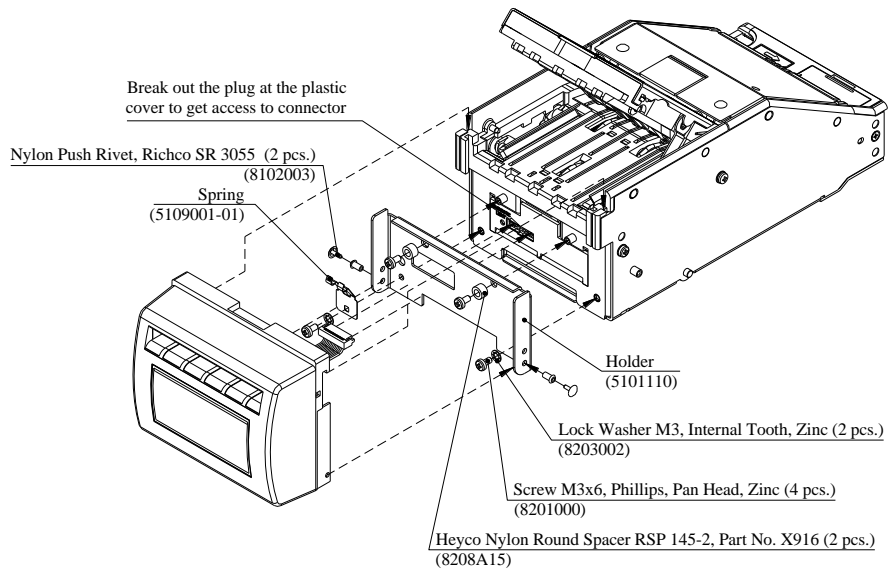

Warning

- Switch power off or disconnect power-interface cable
- Do not touch electrical connectors or cables without using proper electrostatic protection
- Install the spring (5109001-01) using orientation as shown.