

MODEL NAME : KT-1403NA

BUYER : I.G.T

UPDATE : 2003.02.24

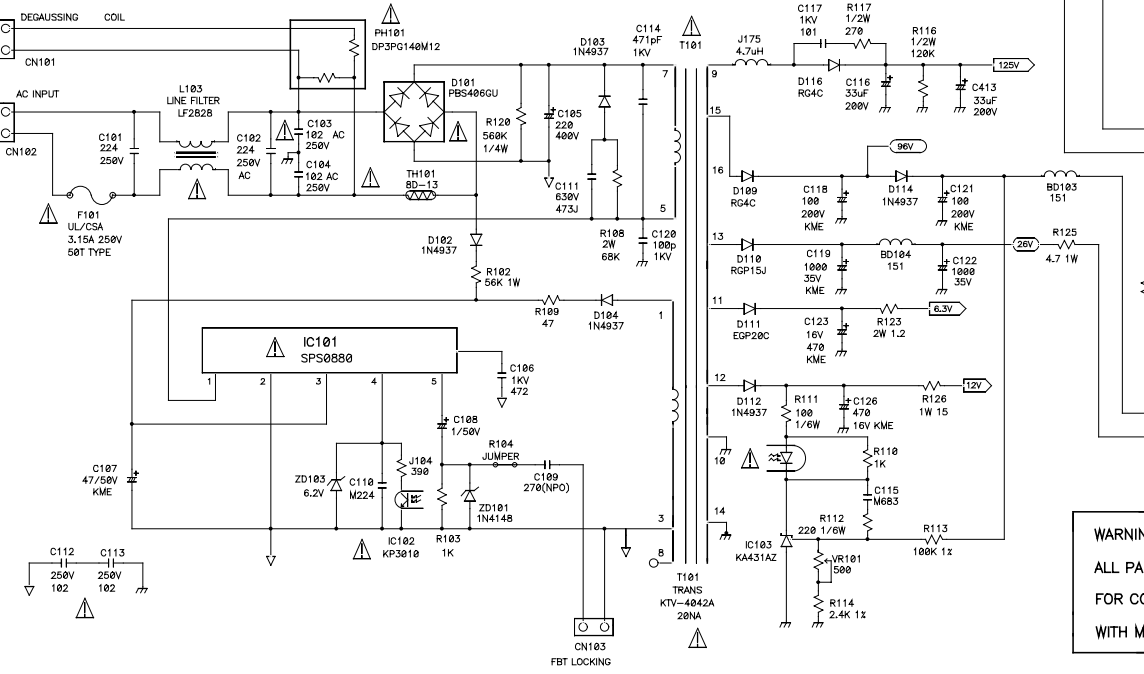
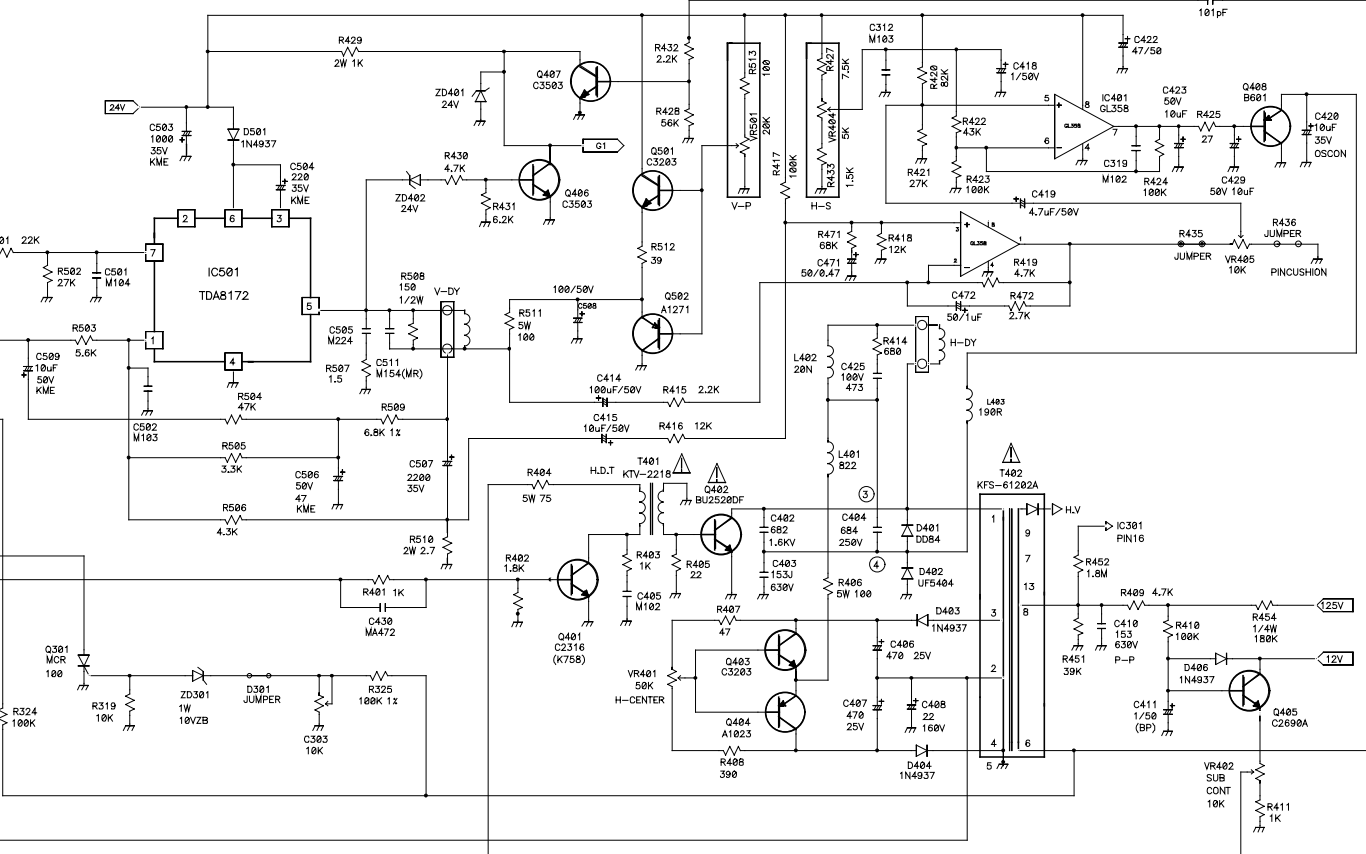
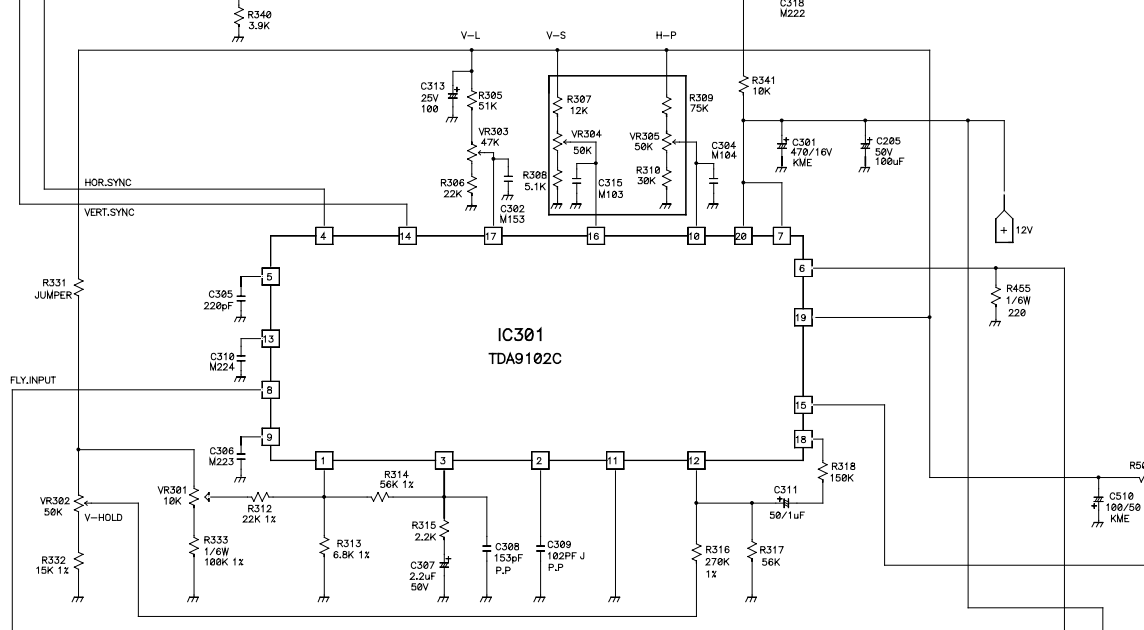
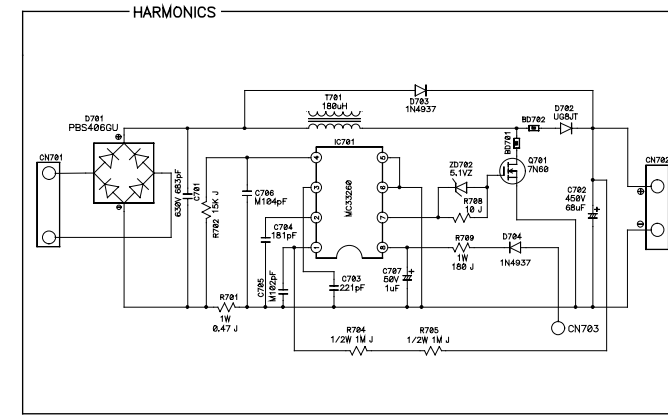
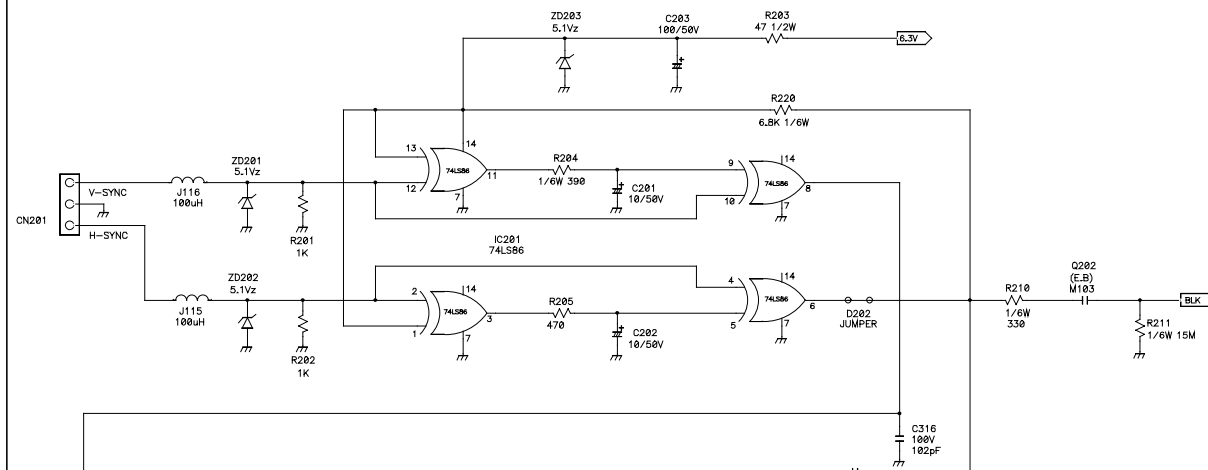

WARNING : THIS EQUIPMENT CONTAINS SAFETY CRITICAL COMPONENTS.
ALL PARTS SHOWN THEMARKS OF THE SCHEMATIC ARE SAFETY CRITICAL
FOR CONTINUED SAEGTY REPLACE SAFETY CRITICAL COMPONENTS ONLY
WITH MANUFACTURERS RECOMMENDED EXACT REPLACEMENTS.

- 1. RESISTOR VALUES ARE IN (OHM). K=1000 . M=1000000.
- 2. ALL RESISTOR ARE 1/4W EXEPT WHERE OTHERWISE INDICATED
- 3. ALL CAPACITOR ARE 50V EXEPT WHERE OTHERWISE INDICATED
- 4. CAPACITOR VALUES ARE UF UNLESS OTHERWISE INDICATED
UF = 10⁻⁶ F

