

MARS® Bill Acceptor

ZT Series 1000

ZT 1200

HIGH, FOUR-WAY ACCEPTANCE

Satisfy customers by accepting bills of all conditions. Bills can be fed in any direction, face up or down.



EXCEPTIONAL SECURITY

Through the use of multiple wavelength optical sensing and sophisticated data processing the ZT Series 1000 bill acceptor sets the standard for rejecting invalid bills. Optical cross-channel sensors examine the bill path for foreign objects such as clear tape or strings. The LRC triggers an automatic "lock out" when separated from the unit for added security.



EASY TO USE

The Recognition and Transport Unit (RTU) and the Lockable Removable Cassette (LRC) can be removed from the front with one hand. The RTU fully opens for cleaning and electrically connects automatically when inserted.

An easily accessible toggle switch enables the operational mode to be changed to "test" or "set-up" mode.

BAR CODE CAPABILITY

Reliably accepts industry standard bar code coupons face up in both directions.

FUTURE FLEXIBILITY IN A FLASH

All US models accept \$1, \$2, \$5, \$10, \$20, \$50 and \$100 bills. The ZT Series 1000 bill acceptor can be easily updated electronically to handle new currency designs.

RELIABLE / LOW MAINTENANCE

With the streamlined recognition system, sensors are embedded under the smooth plastic bill path and the magnetic head and pinch roller have been eliminated to dramatically reduce jams, debris buildup and the need for cleaning.

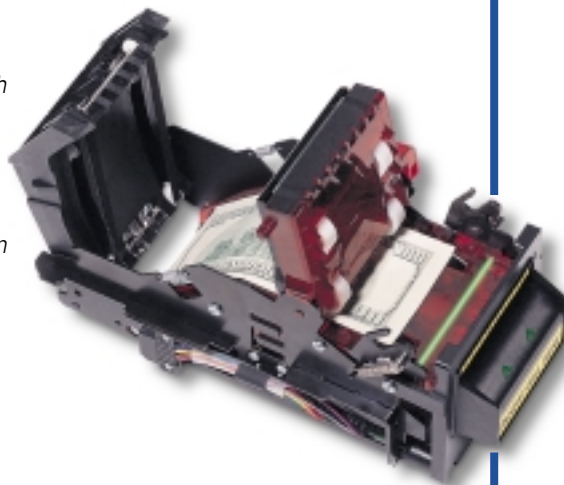

**MARS
ELECTRONICS
INTERNATIONAL**

ZT 1200 MODEL CONFIGURATION & OPTIONS

ZT Series 1000 Bill Acceptor Model Configuration Sample

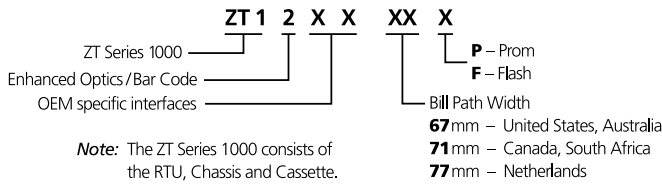

ZT Series 1000 Bill Acceptor Options / Accessories

Part Number	Description
251001048	600 Bill LRC 67-71MM ¹
251009005	600 Bill LRC 72-77MM ¹
251061008	ZT Series 1000 Calibration Kit - 67MM
251061106	MEI Universal Bezel Kit - 67MM
251069107	MEI Universal Bezel Kit - 71MM
251067108	MEI Universal Bezel Kit - 77MM

ZT 1200 ACCEPTOR SPECIFICATIONS

Acceptance Rate

95% or greater for U.S. \$1 thru \$100 bills²

Bill/Barcode Coupon Insertion

Bill/Lengthwise, four way (face up/down, either direction),
Barcode Coupon/face up, either direction

Transaction Speed

Approximately 3 seconds (from bill insertion to completed bill-stacking)

Interfaces

Pulse and multiple serial protocols

Power Sources

12 to 40 volts DC

¹Locks not included ²Contact Mars Electronics for other currency options and specifications.

Power Consumption

Standby: 3.0 Watts, **Acceptance:** 30 Watts peak, **Stacking:** 40 Watts peak

Escrow

One Bill/One Barcode coupon

Shipping Weight

ZT 1200: 11.7 lbs., 600 LRC magazine: 4 lbs. 7oz.

Environment

Operating temperature: 5° C to 50° C

Storage temperature: -30° C to 70° C

Humidity: 5% to 85% Relative Humidity (non-condensing)

ZT 1200 Dimensions

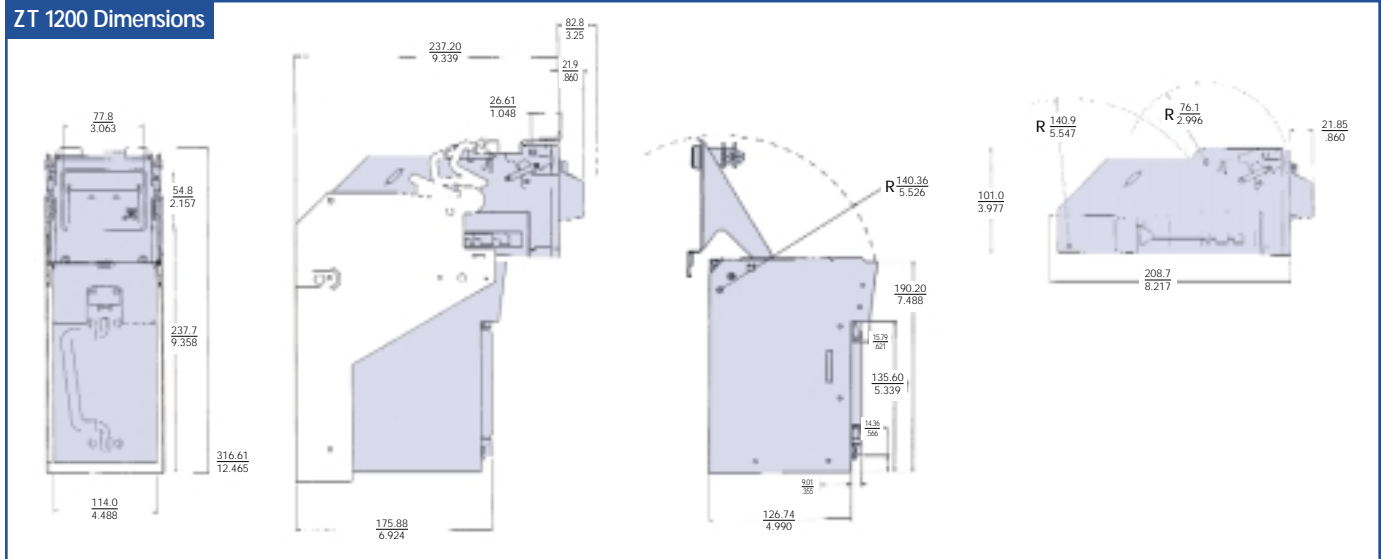

Representative:

UNITED STATES

Mars Electronics International
1301 Wilson Drive
West Chester, Pennsylvania 19380
Tel: 1 610 430 2500
800 345 8215
Fax: 1 610 430 2694

UNITED KINGDOM

Mars Electronics International
Eskdale Road
Winnersh Triangle
Wokingham
Berkshire, RG41 5AQ, England
Tel: 44 118 969 7700
Fax: 44 118 994 6412

SWITZERLAND

Mars Electronics International
109, ch. Pont-du-Centenaire
Plan-les-Ouates
P.O. Box 2650
1211 Geneva 2, Switzerland
Tel: 41 22 884 0505
Fax: 41 22 884 0504

MEXICO

Mars Electronics International
Avenida Santa Rosa de Viterbo #10
Parque Industrial Finsa Bernardo Quintana
Municipio del Marquez
Querétaro, QRO C.P. 76246, Mexico
Tel: 52 42 382000
Fax: 52 42 382001



WEB SITE: www.meiglobal.com • **E-MAIL:** meitech.support@effem.com **OR** meicustomer.service@effem.com

The Mars Electronics International Device is a registered mark. Information is subject to change without notice. Mars Electronics has made every effort to assure that the information in this document is accurate. However, we cannot be held responsible for any errors or omissions.

