

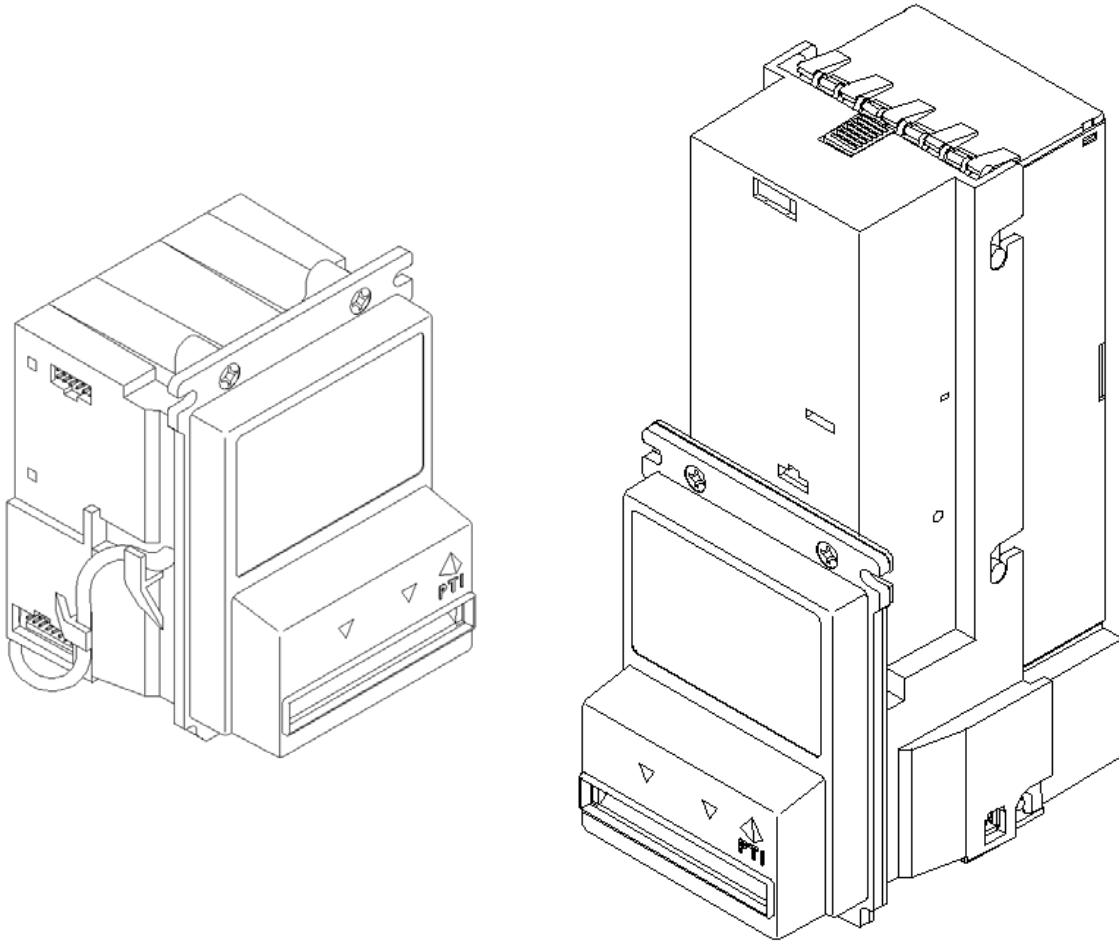

PYRAMID TECHNOLOGIES, INC.



XLC SERIES 5000 BILL ACCEPTOR INSTALLATION/OPERATION MANUAL



Pyramid Technologies, Inc.
1718 N. Quail
Mesa, Arizona 85205 USA
480-507-0088 FAX: 480-507-1922
www.pyramidacceptors.com

Rev. I 08/23/04

TABLE OF CONTENTS

SECTION 1

Product Overview/Features/Specifications	1
Model Number/Serial Number Information.....	2
Dimensional Drawings/Cassette Styles.....	3
Optional Accessories.....	4
Warranty.....	5

SECTION 2

Installation/Mounting.....	6
Configuration/Configuration Card	7-9
Flash Downloading of Software.....	10
Testing.....	11
Troubleshooting/On-Board Diagnostics.....	12-13
Maintenance.....	14

SECTION 3

Interfaces/connector Pinouts for:	
Connector Details	15
Pulse/Serial Mode.....	16-21
Low Level Credit Line Mode-\$1 and \$5 Model Only... ..	22-23
Always Enabled Mode.....	24
RS-232 Mode (True RS-232 and TTL RS-232)	25-26
MDB Mode.....	27
Programming Card (For copying purposes).....	28-29

Note: "VFM, VFM3S, VFM5S, GL5, LE3000 and Mars" are Trademarks of Mars Electronics, International. "HSV-300" is a Trademark of Gamemax. Palm is a Trademark of Palm, Inc.

Product Overview

The Pyramid Technologies, Inc. (PTI) XLC Series bill acceptors are designed for indoor use in the amusement, lottery and kiosk markets. The XLC acceptor can accept \$1 and \$5 bills.

XLC Acceptor Features

- Lighted arrows on bezel and lighted bill entry area.
- High security against fraudulent bills.
- Flash downloadable software using a Palm™.
- On-board pushbutton/LED and advanced diagnostics via Palm™.
- Many interfaces available: Pinouts compatible with other manufacturers' bill acceptors.
- Dual-stage optical anti-stringing.
- Simple configuration and setup.
- 12 VDC (+/- 10%) operation is standard. Optional 120 VAC operation available.
- Removable bill path for easy cleaning.
- Can handle bills up to 72 mm wide for foreign applications.
- 200, 500 and 1000 bill cassettes available (stackered model).
- Auto-calibration - Never needs to be calibrated.

Product Specifications

Operating Voltage: 12 VDC (+/- 10%) standard, optional 120 VAC supply available.

Operating Currents: Idle: 180 mA **Accepting:** 500 mA **Stalled:** 1.50 A.

Operating Temperature: 0C – 60C, 90 % non-condensing humidity.

Acceptance Rate: Greater than 95%, including second time insertion of a rejected bill.

Acceptance Speed: Approx. 20 bills per minute.

Sensor Array: 8 Optical Sensors

Net Weight: Stackered Model..... 2.3 lbs./1.04 kg.

Stackerless Model..... 1.0 lbs./0.45 kg.

Warranty: 1 year, parts and labor (see Warranty Section, page 5).

To order any XLC Series acceptor, use the following order information:

Series	Model	Type	Cashbox	P.S./Comm.	Country
XLC	- 5200-	X	X	X	- XXX

Model

5200

Type

- S- Stackerless
- U- Upstacker
- D- Downstacker

Cashbox

- N- None (Stackerless only)
- 2- 200 Bill Cassette
- 5- 500 Bill Cassette
- 1- 1000 Bill Cassette

P.S./Comm. (Power Supply/Communication Options)

- 1- 12 VDC (No harness supplied)
- 2- Low Cost 120 VAC supply (Ships with 9-pin AC harness)
- 3- 120 VAC supply (Ships with 9-pin AC harness.)
- 4- MDB Option (Ships with MDB harness)
- 5- True RS-232 Option, 12VDC operation (Ships with DB-9/hard drive connector harness)

Country Code

Follows ISO three (3) digit Country Code
 Software currently available:
 USA (United States)

Serial Number Description

Example Serial Number: S/N 0238 00001

In this example, the first two digits are the year of manufacture (**2002**).
 The week of manufacture is week **38** of 2002.
 The sequential production serial number is **00001**.

Dimensional Drawings- Stacked and Stackerless Cassette Styles

The stacked XLC bill acceptor can be ordered with either a 200, 500 or a 1000 bill cassette. The cassette has a cover that can easily be opened to retrieve the bills without removal of the cassette from the acceptor.

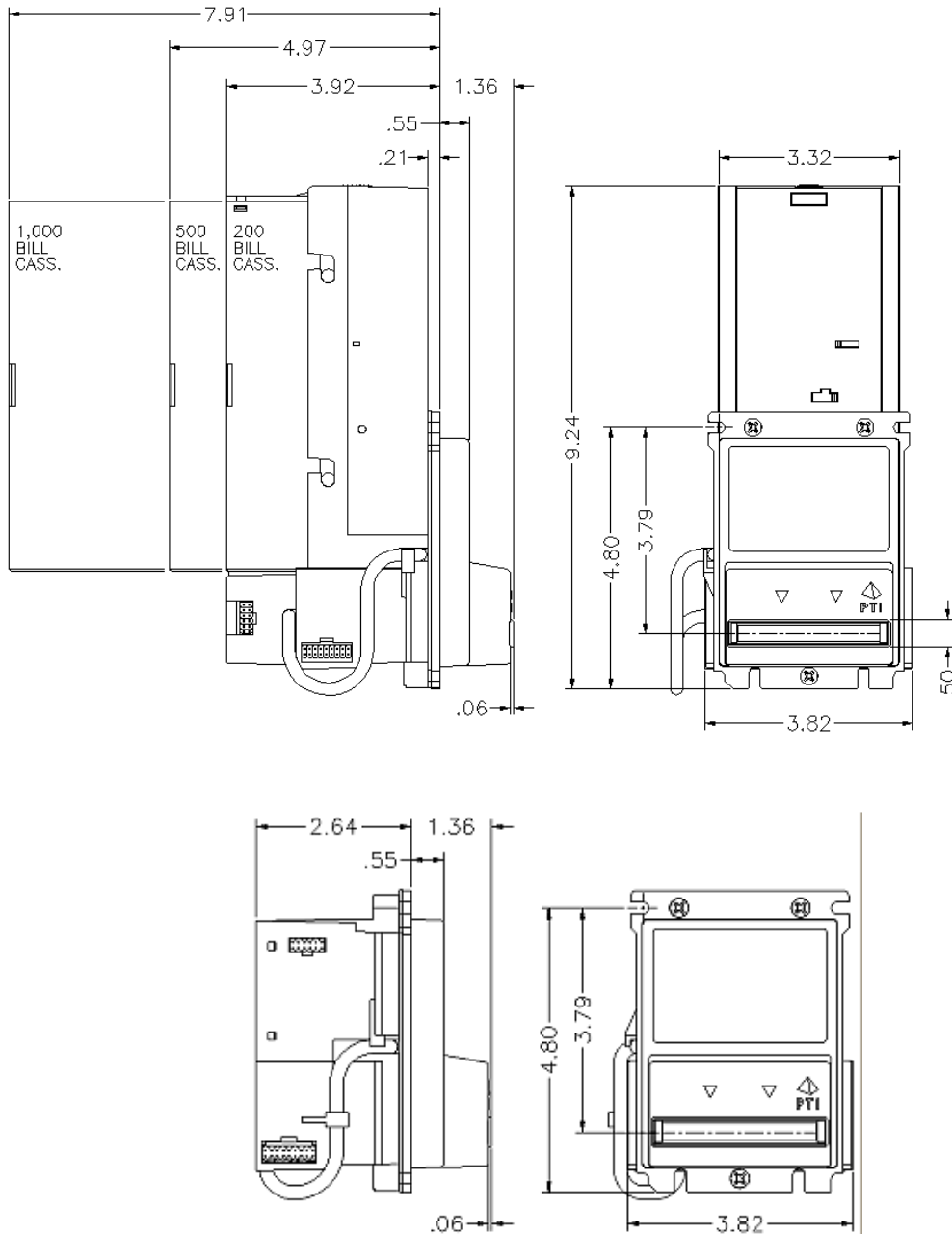

The following is a list of optional accessories available from Pyramid Technologies, Inc.

Description**Part Number****Acceptor I/O Harness, Generic****P/N 05AA0002**

This is an 18-pin harness to interface to the XLC bill acceptor I/O. All 18 wires are present. The wires are 36" long.

HSV-300™ Compatible I/O Harness**P/N 05AA0007**

This harness plugs into our 18-pin I/O connector on the XLC bill acceptor and allows the user to connect the acceptor directly to a harness originally intended for an HSV-300 acceptor. This harness is a seven (7) pin connector and is 6" long

Flash Download (Palm) Interface Harness **P/N 05AA0011**

This harness is used to interface a Palm to the XLC bill acceptor. This harness is used for acceptor diagnostics and flash software downloading. Please visit <http://www.pyramidacceptors.com> and go to the "Download" section to download the Palm program. For complete Palm documentation, see the "Support " section of the web site. These files are also available upon request.

Adapter Bracket Kit**P/N 98AB0010**

This kit is used to mount the XLC bill acceptor to a wood door. This kit comes with all necessary mounting hardware.

RS-232 Communication Harness**P/N 05AA0009**

This harness is needed for true RS-232 communication. The harness comes with a DB9 connector on 36" of cable, as well as a hard drive connector on 36" of cable to obtain 12 VDC power for the bill acceptor from the PC. Order Document "RS_232.pdf" for more details (or visit our web site). The "Download" section of our web site has a demo program which you can download to try out the PC interface.

MDB Communication Harness**P/N 05AA0010****MDB Communication Board****P/N 04AA0007**

Both the harness and board are needed for MDB communication. The harness comes with an MDB style connector.

Limited Warranty

XLC bill acceptors are warranted for a period of one (1) year from date of original invoice. This warranty extends to the original purchaser of the warranted product and each transferee owner of the product, during the term of the warranty. During the warranty period, manufacturer will repair or replace (at manufacture's option) any parts, up to and including the complete acceptor, which fail to function properly because of defects in material or workmanship.

This warranty covers bill acceptors only, which are designed to accept genuine currency.

Manufacturer is not responsible for any consequential damage or performance degradation that results from counterfeit currency or foreign objects inserted into the bill acceptor. The product to be repaired under warranty must be delivered, inbound freight prepaid to an authorized service center. Upon request, the owner must show proof of purchase when submitting equipment for service during the warranty period. Repair or installation at the owner's location is not included in warranty. During the warranty period, manufacturer will pay all outbound ground freight charges to the owner's location. Special handling or shipping charges must be assumed by the owner. Manufacturer will not be liable for any consequential damages as a result of defects in material or workmanship. Any written or applied warranty of this product is strictly limited to the refund of the cost of goods purchased. Damage due to negligence, accidents, electrical overload, misuse, abuse, vandalism, or an act of God, is not covered by this warranty. Any alteration of the product after manufacture voids the warranty in its entirety.

Shipping Damage

When a product is returned to the owner after service, only consignee (the person or company receiving the bill acceptor) can file a claim against the carrier for concealed damages. Therefore, unpack immediately. Notify the delivery carrier of damages and request immediate inspection. Send a letter of intent to file claim to the carrier within 72 hours from the time of receipt. Send a copy of this letter to the shipper.

Service

For service information, please contact Pyramid Technologies, Inc. for a Service Center near you. For any items returned under warranty or for repair, complete written information including the serial and model number as well as a description of the malfunction or defects must be submitted to the Service Center when requesting a Return Material Authorization number (RMA number). Owner accepts full responsibility for any return without prior authorization. The RMA number must be displayed on the exterior of the returned product carton(s).

Unpacking the Bill Acceptor

Immediately inspect the bill acceptor for damage when unpacking it. If the acceptor is damaged, place it back in its original carton along with the packing materials.

Notify the carrier of damages and request an immediate inspection of the package. Send a letter of intent to file a claim to the carrier within 72 hours from time of delivery. Please also send a copy of this letter to the shipper. Only the person or company receiving the bill acceptor can file a claim against the carrier for concealed damages.

Installation/Mounting

The XLC bill acceptor has been designed to easily mount onto existing studs in OEM equipment. If you are mounting the acceptor to a wood panel or door, you may require our optional Adapter Bracket **(P/N 98AB0010)**.

To install the acceptor:

- Disconnect all power to the machine.
- Connect the interface cable from the machine to the acceptor.
- On 120 VAC units, connect the 9-pin power plug to the machine. Install the green ring terminal ground wire to a stud that is part of the grounded frame.
- Secure the harnesses in place using the provided tie wraps.

The XLC bill acceptor has no DIP switches. It can be factory programmed to exactly fit your needs, or you can configure it using one of two methods. The first method is using the Configuration Card. This simple card allows you to program all features of the bill acceptor. The second method is using a Palm or in conjunction with our Flash Interface Cable (P/N 05AA0011). Using this method, you can quickly configure the bill acceptor. Please note that power must be applied to the bill acceptor to use either configuration method.

Configuration using a Palm

This method allows you to change the configuration of the XLC acceptor easily. Please order Document “XLC Palm Tools” for more details. See the section on Flash Programming for more details.

Configuration using the Configuration Card

The XLC acceptor can be configured using a Configuration Card. A Configuration Card is printed on the last page of this manual. To use this card, first make a copy using a standard black and white laser or bubble jet copier. Make sure the copy is printed on white copier paper and is the same size as the original card. Note: Copiers occasionally change the size of printed materials. This is why you should compare the copied card to the original card.

Once you have copied the card in the manual, carefully cut it out along the edge lines.

The Configuration Card shown below is for example only!

Use the card in the back of this manual!

INSERT THIS SIDE UP, THIS END FIRST
USE BLACK INK, FILL OVALS COMPLETELY

<p>section 1</p> <p>Pulse Serial <input type="checkbox"/> \$185</p> <p>Credit Lines <input type="checkbox"/> \$1-20</p> <p>MD8 <input type="checkbox"/> Always Enable</p> <p>RS-232 <input type="checkbox"/> Parallel</p> <p>Special 1 <input type="checkbox"/> Special 2 <input type="checkbox"/></p>	<p>section 2</p> <p>Pulses per minute <input type="checkbox"/> 64</p> <p>Turn of selected values <input type="checkbox"/> 32</p> <p><input type="checkbox"/> 16</p> <p><input type="checkbox"/> 8</p> <p>None <input type="checkbox"/></p>	<p>section 3</p> <p>Pulse Speed: <input type="checkbox"/> Slow <input type="checkbox"/> Fast</p> <p>Lighted Bezel: <input type="checkbox"/> Solid On <input type="checkbox"/> Flashing</p>	<p>section 4</p> <p>Select Bills to Enable</p> <p>Bill 1 (\$1) <input type="checkbox"/> Bill 2 <input type="checkbox"/> (\$5)</p> <p>Bill 3 (\$10) <input type="checkbox"/> Bill 4 <input type="checkbox"/> (\$20)</p> <p>Bill 5 (\$50) <input type="checkbox"/> Bill 6 <input type="checkbox"/> (\$100)</p> <p>Bill 7 <input type="checkbox"/> Bill 8 <input type="checkbox"/></p> <p>Bill 9 <input type="checkbox"/> Bill 10 <input type="checkbox"/></p> <p>Bill 11 <input type="checkbox"/> Bill 12 <input type="checkbox"/></p>
<p>section 5</p> <p>Security Level: <input type="checkbox"/> High <input type="checkbox"/> Low</p> <p>Insert Direction: <input type="checkbox"/> Face Up <input type="checkbox"/> Face Down</p>	<p>Example: For 50 ppm, fill in the ovals for 16, 8, and 32 (32+16+8 = 50)</p> <p>Example: USA \$1, \$5, and \$10. fill in the ovals for Bill 1, Bill 2, and Bill 3.</p>		

This Configuration Card should be printed on standard copy paper, measuring 6.3 x 2.8 inches (162 x 68 mm). If printing from a .PDF file, turn off the "shrink to fit" option in your printer settings for proper scale.

PYRAMID TECHNOLOGIES, INC.
CURRENCY VALIDATION EXPERTS

Once configured with the card, the acceptor will remember these settings, even if power is removed.

When you fill in the card, use a black felt tip marker and fill the selected block completely making sure no marks are outside the block.

Note: As a service to our customers, Pyramid Technologies, Inc. will configure each acceptor to your requirements free of charge. Just ask!

Fill out the Configuration Card according to the table below:

Section Number on Configuration Card	Description
<p>Section 1 These lines select the type of Interface that you want to use. If you are unsure about your selection, see the Interface Section (Section 3) of this manual. You can select only <u>one</u> interface type.</p>	<p>Pulse/Serial- Mars™ - Pulse or 600 baud serial. \$1/\$5 Credit Lines- Similar to Mars VFM3™. (Will only operate on XLC 5200 Series acceptors.) MDB – Multi-Drop Bus interface mode. \$1-\$20 Credit Lines- (not available with XLC). RS-232- True RS-232 or TTL RS-232 interface. Always Enabled- Acceptor always enabled mode. Parallel – (not available with XLC). HI Interface-(not available with XLC). Special1- Customer specific interface. Special2- Customer specific interface.</p>
<p>Section 2 These lines select the Pulses Per Dollar. For Pulse mode, fill in the Blocks to add up the total number of Pulses Per Dollar that you desire. Note: For \$1/\$5 Credit Line Mode: If you want to use the credit lines for output (non-isolated mode), select “None”. If you are using the relay output (isolated mode), select the pulses per dollar that you desire. Fill out “None” if you are not using any type of pulse mode.</p>	<p>Fill in the Blocks to add up the total number of Pulses Per Dollar that you desire. For example, if you want ten (10) pulses per dollar, fill in the “8” and “2” Blocks. Note: If you wish to use the Mars 600 baud serial mode instead of Pulse, then fill in the “None” Block. The software will read this and understand that you are selecting the Mars Serial mode. If you select a number for Pulses Per Dollar, the acceptor <u>always</u> assumes Pulse Mode (this eliminates the need for the usual “Pulse Jumper Plug”).</p>
<p>Section 3 (Pulse Speed) This line selects the Slow or Fast Pulse. The Slow Pulse is a 50 msec on, 300 msec off pulse. The Fast Pulse is a 50 ms on, 50 ms off pulse.</p>	<p>Fill in the appropriate Block. Note: If you are not using the pulse mode, don’t fill out this section.</p>
<p>Section 3 (Lighted Bezel) This line selects how the Bezel lighting will appear to the customer. The Bezel can be selected to be always on when the acceptor is enabled, or can set to be flashing when the acceptor is enabled. In either case, the Bezel is off when the acceptor is disabled, or when the acceptor has a problem.</p>	<p>Fill in the appropriate Block. You must select one of the options here.</p>
<p>Section 4 (Enable Bills) These lines determine which bills you want enabled.</p>	<p>Fill in the appropriate Block to enable a bill. The other lines labeled “Bill 7” through “Bill 12” are for special bills or custom configurations only.</p>

(Table Continued from the previous page)

Section Number on Configuration Card	Description
<p>Section 5 (Security Level) This line is used to select the security of the bill acceptor. Select either low or high security.</p>	<p>Low security should be used when the environment is monitored by personnel, or when the user knows that the likelihood of counterfeiting is low. High security should be selected for environments that are not monitored, or when the acceptor is configured to accept high denomination currency. You must select one option.</p>
<p>Section 5 (Insert Direction) This line is used to select the direction of bill acceptance. Bills can be accepted in all four directions or “Face up, left” which means face up, black seal first.</p>	<p>Select the appropriate direction of insertion. You must select one option.</p>

Inserting the Configuration Card into the Bill Acceptor

Once you have selected the desired configuration of the bill acceptor, you can now use this card to program the bill acceptor. To perform a configuration, the acceptor must have power applied. The game or host interface does not need to be connected. Only power to the acceptor is required.

Configuring the Bill Acceptor

- Make sure power is applied to the bill acceptor.
- Press and hold the Diagnostic Pushbutton located at the left rear of the bill acceptor (looking at the acceptor from the rear). Hold the Diagnostic Pushbutton for at least ten (10) seconds, then release.
- The bezel lighting on the front of the acceptor will flash ten (10) times.
- Insert the Configuration Card into the acceptor, arrows first, printed side face up.
- The acceptor will hold the Configuration Card for a second or two, then feed it back to you.
- If the bezel lights are flashing rapidly, the acceptor has read the Configuration Card correctly. The configuration is now in permanent memory in the bill acceptor. The acceptor will reset itself. You can now begin using the acceptor.
- If the bill acceptor has not read the Configuration Card correctly, the bezel lights will flash slowly a certain number of times. The number of flashes will tell you which Section of the card it cannot read correctly. If this occurs, make sure that Section is filled in neatly. The bill acceptor will stay in the Configuration Mode until it has correctly read a Configuration Card, or if you remove power to the acceptor.

Downloading new software to the XLC bill acceptor is accomplished using a Palm™. If you wish to change the software inside the acceptor, you must have an approved version of these devices. Request document “XLC_Palm_Tools” for more details, or visit our web site.

Flash Programming Primer

Instead of using an EPROM to hold the bill acceptor software, Pyramid Technologies, Inc. chose to use a Flash Device installed on the XLC bill acceptor’s Microprocessor Board. Using this device, there is no need to open the acceptor to change software. To change the acceptor’s software, you will plug a Palm into the six (6) pin connector located next to the Diagnostic Pushbutton (left rear of the acceptor as seen from the back). You also need to purchase the required Flash Interface Harness, P/N 05AA0011. After loading the required software onto the Palm, you can download new software to any bill acceptor at any location. The only requirement is that the acceptor has power applied. This method has the added benefit of allowing the Palm to be able to perform advanced diagnostics on the bill acceptor. This makes for an excellent troubleshooting device.

Our web site (www.pyramidacceptors.com) has the latest available software located in our “Download” Section, and documentation is available upon request, or from the “Support” section of our web site.

Palms are available from Pyramid Technologies, Inc. or you may purchase an approved device yourself.

Bill Acceptor Testing

- Apply power to the machine. The bill acceptor will cycle its motor and stacker, if so equipped.
- Check the bezel lighting. Based on the configuration you programmed, the bezel lights should be on solid or flashing at a one second rate. This will indicate that the acceptor is ready to take bills.
- Insert one of each denomination that can be accepted and verify that proper credit is given to the machine.
- If the acceptor does not accept a particular bill or does not credit the machine properly, re-check the configuration that you programmed using the Configuration Card.

The XLC Series bill acceptors have built in diagnostic abilities. These can be accessed using the Diagnostic Pushbutton, located at the left rear of the bill acceptor (viewed from the back).

Pushbutton Operation

The Diagnostic Pushbutton on the XLC bill acceptor is utilized for two functions. They are:

1. Diagnostics of the acceptor using the front bezel lighting.
2. Configuration of the acceptor using the Configuration Card.

Refer to Configuration/Configuration Card Section (pages 7-9) for details on configuring the acceptor.

Diagnostic Features

To enter the Diagnostic Mode, the acceptor must have power. The front bezel lighting is used to flash a certain number of times to indicate an error, if one exists.

To enter the Diagnostic Mode, push and hold the Diagnostic Pushbutton located at the left rear of the acceptor (viewed from the back). Hold it for at least one (1) second, but no more than five (5) seconds, then release.

Note: Holding it longer than 10 seconds will put the acceptor into a Configuration Mode and it will expect to have the Configuration Card inserted next. If you have accidentally entered this mode, cycle the acceptor power and start again.

Look at the front bezel of the bill acceptor. It will be flashing the bezel lights on and off. The number of times the lights flash corresponds to the error code listed on the next page.

To exit this mode, either let the acceptor sit (it will automatically exit this mode after thirty (30) seconds), or press the button again for 1-5 seconds. (Remember, don't hold for longer than five (5) seconds.)

Front Bezel Lighting Flash Codes

The flash codes shown correspond to the XLC bill acceptor error. The acceptor will flash the error code, then wait 3 seconds and flash it again.

Flashing Code	Meaning of Flashing Code	Corrective Action
LED's always OFF	The acceptor has no power.	Check that power has been applied.
LED's always ON	No error exists- acceptor is OK.	None.
1 Flash	Something is in the bill path.	Remove the cassette and Lower Transport to inspect for foreign objects. Clean if necessary.
2 Flashes	Something is obstructing the stacker.	Remove the cassette and Lower Transport to inspect for foreign objects. Clean if necessary.
3 Flashes	The cassette is full of currency.	Remove the cassette and empty it.
4 Flashes	The cassette has been removed.	Replace the cassette.
5 Flashes	The acceptor is defective.	Replace the acceptor.
6 Flashes	The acceptor is not enabled.	Verify that the host has enabled the acceptor.
10 Flashes	Configuration Mode has been entered.	Configuration Card must be inserted into the acceptor or cycle power to the acceptor to exit this mode. See Configuration Section (pages 7-9) for details.
Rapid Flashing During Operation	The acceptor has detected a stringing attempt, or the optical anti-stringing sensor is dirty.	Remove the Lower Transport and clean the optical anti-stringing sensor pair openings. These sensor openings are located on the Lower Transport, about ½ " behind the round, white plastic rollers, and to the far left and right of the bill path. It is a good idea to clean all of the sensors at this time, both the entire upper and lower halves of the bill path. Reinstall the Lower Transport and cycle the power.

Maintenance

The XLC Series bill acceptor is relatively maintenance free. An occasional cleaning is all that is needed to keep the acceptor in top operation. To clean the acceptor:

- Remove power from the machine.
- If equipped with a stacker, unlatch the cassette by pushing in the top latch and lifting the cassette up and out.
- Unplug the I/O connector and/or power connector from the right side of the acceptor. Note: You cannot remove the Lower Transport without first removing the I/O connector!
- Remove the Lower Transport by pushing in the latch located on the bottom of the acceptor at the rear. Gently pull the Lower Transport out of the assembly.
- Clean the bill path using a soft cloth or towel. Do not use any cleaners other than a 50/50 mixture of water and isopropyl alcohol.

NOTE: Pay particular attention to the gray oval pieces of plastic in the lower and upper transport area. They must be cleaned well for proper operation.

- Do not use any oils or silicon spray on the acceptor!

Connection Details

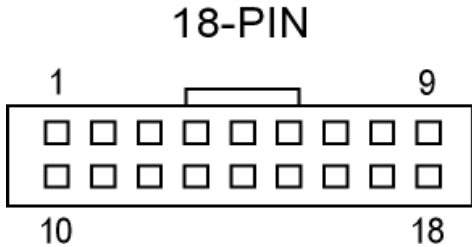

18-pin I/O connector
(looking at the acceptor)

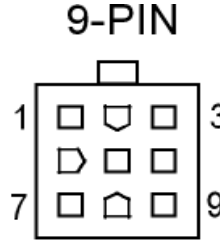

9-pin 120 VAC connector
(view of connector)

Note: Some connections only available on certain models. See following pages for details.

18-pin Mating Connector

Amp "Modu" 18-pin, P/N 102398-7 (IDC Housing)
Amp Back Cover P/N 102536-7
Amp Front Cover P/N 102681-4

9-pin Mating Connector

Amp Mate-N-Lock 9-pin P/N 172161-1
Amp Pin, Male P/N 170364-1

Pin	18-Pin Connector Function (wire color)
1	\$1 Low-level credit line output (Brown)
2	~INT line for Mars 600-baud mode (Orange)
3	Serial/~Pulse or ~\$5 for \$1/\$5 mode (Yellow)
4	DC Power Ground (Black)
5	TXD for Mars 600 or TTL RS232 (Green)
6	High Escrow Line for \$1/\$5 mode or ~\$1 Enable for GL5 mode (Blue)
7	\$5 High Enable for \$1/\$5 mode (Gray)
8	~\$5 Low Enable for GL5 mode (Pink)
9	\$1 High Enable for \$1/\$5 mode or ~\$10 Low Enable for GL5 mode (White)
10	Out of Service line (pulled low) (Tan)
11	+12 VDC Power (Red)
12	~Acceptor Enable (Pull low to enable) (Violet)
13	330 Ohm resistor to +5 VDC for LED (White/Orange)
14	~Send line for Mars 600 or Low ~Escrow line for \$1/\$5 mode (White/Blue)
15	~\$1 Low Enable for \$1/\$5 mode (White/Yellow)
16	RXD for TTL RS232 (White/Red)
17	~\$5 Low Enable for \$1/\$5 mode (White/Green)
18	~Escrow Low Enable for \$1/\$5 mode or ~\$20 Low Enable for GL5 mode (White/Gray)

Pin	9-Pin Connector Function
1	120 VAC Neutral Inhibit
2	120 VAC Neutral Enable
3	120 VAC Hot Enable
4	120 VAC Hot Power
5	No Connection
6	120 VAC Neutral Power
7	Bill Acceptor Relay Contact
8	Bill Acceptor Relay Contact
9	No Connection

Pulse/Serial Mode

Note: To enable this mode on the XLC bill acceptor, make sure the Configuration Card has been configured for “Pulse/Serial” mode.

These modes are compatible with the Mars VFM style bill acceptors that use the Pulse/Serial modes. Figure 1 shows the connectors to be used for this mode of operation.

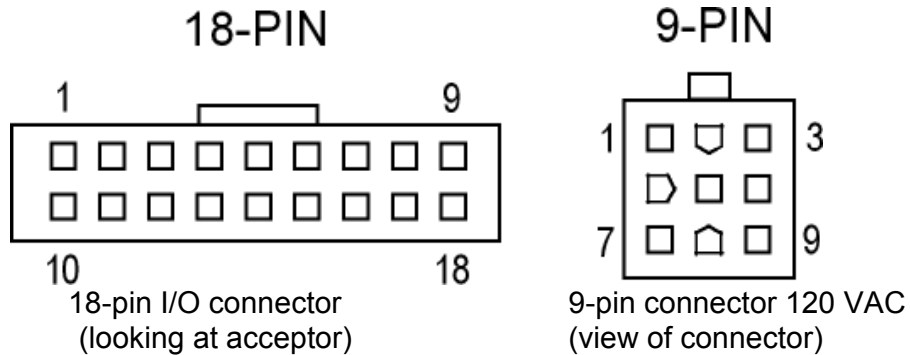

Figure 1

18-pin Mating Connector

Amp “Modu” 18-pin, P/N 102398-7 (IDC Housing)
 Amp Back Cover P/N 102536-7
 Amp Front Cover P/N 102681-4

9-pin Mating Connector

Amp Mate-N-Lock 9-pin P/N 172161-1
 Amp Pin, Male P/N 170364-1

Pulse Mode

The pulse interface mode can be operated in two ways. The first is a “High Level” mode that uses 120 VAC as the control signals. The second is a “Low Level” mode that uses low voltage signals (see next page).

High Level Pulse Mode

This interface is typically used in can vending machines. It uses 120 VAC to enable/disable the acceptor. The output of the bill acceptor is a pulse output via relay contacts. You must be using Pyramid Technologies, Inc. optional 120 VAC power supply for this mode to work.

High Level Pulse Mode- Inputs and Outputs

The inputs and outputs (I/O) are located on the 9-pin connector and 18-pin connector (Figure 1 shown on page 16) for the High Level Mode.

The I/O descriptions for the 9-pin connector are as follows:

Pin 4- 120 VAC Hot (Black wire). Connect to 120 VAC Hot (for AC power).

Pin 6- 120 VAC Neutral (White wire). Connect to 120 VAC Neutral (for AC power).

Pin 3- 120 VAC Hot Enable (Red wire). Connect to 120 VAC Hot to enable acceptor. Leave floating to disable acceptor. **(Note: Low cost 120 VAC supply does not have this connection. It is a no-connect.)**

Pin 2- 120 VAC Neutral Enable (Orange wire). Connect to 120 VAC Neutral to enable acceptor. Leave floating to disable acceptor. **(Note: Low cost 120 VAC supply does not have this connection. It is a no-connect.)**

Pin 1- 120 VAC Neutral Inhibit (Green wire). Connect to 120 VAC Neutral to disable acceptor. If left floating, may disable acceptor, based on the state of the 120VAC Hot Enable line. **(Note: Low cost 120 VAC supply does not have this connection. It is a no-connect.)**

Pins 7 and 8- (Brown wire-7, Blue wire-8) Bill acceptor relay contacts capable of 1 amp resistive load at 120 VAC. Based on how you configured the acceptor, they will put out a 50 msec on/50 msec off pulse, or a 50 msec on/300 msec off pulse. Due to relay contact bounce, it is recommended that the software engineer incorporate a 10 msec software delay to debounce the relay contacts.

The I/O descriptions for the 18-pin connector are as follows:

Pin 3 (Yellow wire)- Serial/~Pulse Line. Pull low (Connect to Pin 4 (Black wire), which is Ground) to enable the Pulse mode of operation. **Note:** You **do not** need to make this connection if you have selected "Pulse/Serial" on the Configuration Card and you have specified some number for the Pulses Per Dollar. By selecting some number for Pulses Per Dollar, you have told the acceptor that you are in Pulse mode, not Mars Serial Mode. This eliminates the need for this connection, commonly called a "Pulse Jumper Plug".

In addition, both the 120 VAC model and 12 VDC model have an "Out of Service" output located on Pin 10 (Tan wire) of the 18-pin connector. It is a normally high, open-collector output transistor that is pulled low when the acceptor is Out of Service. (5-12 VDC at 40 mA Max.) Pin 13 (White/Orange wire) of the 18-pin connector has a 330 ohm resistor tied to +5VDC to power an LED.

Low Level Pulse Mode

The Low Level Pulse Mode can operate using either the optional 120 VAC power supply, or by using 12 VDC applied to the bill acceptor. Using the optional 120 VAC power supply, the output can be taken from the relay contacts (Pin 7 and 8 on the 9-pin connector). Without the 120 VAC power supply, the output is on the 18-pin connector and is a normally high, open-collector transistor output.

Low Level Pulse Mode- Inputs and Outputs

Power

120 VAC Model- Connect 120 VAC power to Pins 4 (Black wire) and 6 (White wire) on the 9-pin connector (see Figure 1 on page 16).

12 VDC Model- Connect +12 VDC to Pin 11 (Red wire) on the 18-pin connector (see Figure 1 on page 16). Connect DC ground to Pin 4 (Black wire) on the 18-pin connector.

Inputs (0-5 VDC Operation Only)

Pin 12 (Violet wire) on the 18-pin connector- Accept Enable line. Bring low to enable the acceptor. (Tie to DC ground, Pin 4 (Black wire) on the 18-pin connector to always enable the acceptor.)

Pin 3 (Yellow wire) on the 18-pin connector- Serial/~Pulse Line. Pull low (connect to Pin 4 (Black wire), which is DC Ground) to enable the Pulse Mode of operation. **Note:** You **do not** need make this connection if you have selected "Pulse/Serial" on the Configuration Card and you have specified some number for the Pulses Per Dollar. By selecting some number for Pulses Per Dollar, you have told the acceptor that you are in Pulse Mode, not Mars Serial Mode. This eliminates the need for this connection, commonly called a "Pulse Jumper Plug".

Outputs

120 VAC Model- You can use the relay output on Pins 7 (Brown wire) and 8 (Blue wire) of the 9-pin connector, or you can use the normally high, open-collector output transistor on Pin 1 (Brown wire) on the 18-pin connector. (5-12 VDC at 40 mA Max.)

12 VDC Model- Use the normally high, open-collector output transistor on Pin 1 (Brown wire) on the 18-pin connector (5-12 VDC at 40 mA Max.).

In addition, both the 120 VAC model and 12 VDC model have an "Out of Service" output located on Pin 10 (Tan wire) of the 18-pin connector. It is a normally high, open-collector output transistor that is pulled low when the acceptor is Out of Service. (5-12VDC at 40 mA Max.) Pin 13 (White/Orange wire) of the 18-pin connector has a 330 ohm resistor tied to +5VDC to power an LED.

Serial Mode- (Works with both 12 VDC and 120 VAC models of the XLC Bill Acceptor.)

The Pyramid Technologies, Inc. Serial Interface is Mars compatible. This interface is a non-isolated interface. (TTL/CMOS compatible.) This interface operates at 600 baud, 1 start bit, 1 stop bit and 8 data bits.

The XLC bill acceptor will pull the Interrupt line low when it has a serial message to send to the host. The host machine will pull the Send line low when it can receive this serial message. The XLC will then output a Credit Message if the bill is recognized. A Reject Message is sent if the bill is not recognized. After the Credit message is sent to the host, the Enable line is to be pulsed high within 5 msec if the host wants to return the bill to the customer. If the Enable Line remains low, the acceptor will accept the bill and send a Vend Message to the host. The Host machine can tell the acceptor to resend any particular message by bringing the Send Line high and pulse it low within 2-4 msec.

Serial Mode- Inputs and Outputs**Power**

120 VAC Model- Connect 120 VAC power to Pins 4 (Black wire) and 6 (White wire) on the 9-pin connector (see Figure 1 on page 16).

12 VDC Model- Connect +12 VDC to Pin 11 (Red wire) on the 18-pin connector (see Figure 1 on page 16). Connect DC Ground to Pin 4 (Black wire) on the 18-pin connector.

Serial Mode(Continued)- Inputs and Outputs**Inputs and Outputs (Inputs are 0-5V DC Operation Only)**

The table below shows the Connections for the Serial Interface.

Pin Number wire Color	Signal Name	Function
Pin 2 Orange wire	~Interrupt Line	Request to send data to host.
Pin 3 Yellow wire	Serial/Pulse Mode Select Line	Must be left floating to enable serial mode. (No Connect.) Also make sure you have selected "None" for all Pulses Per Dollar selections on the Configuration Card.
Pin 4 Black wire	Ground	DC ground
Pin 5 Green wire	TXD (Data Output)	Transmit Data Line from acceptor.
Pin 10 Tan wire	Out Of Service	Pulled low by the acceptor when the acceptor is out of service or when the stacker (if so equipped), is full. (5-12 VDC at 40 mA Max.)
Pin 11 Red wire	+12 VDC Power	+12V Acceptor Power. Note: Do not connect if the optional 120 VAC supply is used!
Pin 12 Violet wire	Acceptor Enable	Pull low to enable the acceptor.
Pin 13 White/Orange wire	LED Power	LED Power can be obtained here. This output is a 330 ohm resistor tied to +5V.
Pin 14 White/Blue wire	~Send Line	Host Ready Signal.

Serial Mode(Continued)

The table below shows the Data that can be sent from the XLC bill acceptor to the Host.

Message	Bit 7	Bit 6	Bit 5	Bit 4	Bit 3	Bit 2	Bit 1	Bit 0	Hex Value
\$1 Credit	1	0	0	0	0	0	0	1	81H
Not Used	1	0	0	0	0	0	1	0	82H
\$5 Credit	1	0	0	0	0	0	1	1	83H
\$10 Credit	1	0	0	0	0	1	0	0	84H
\$20 Credit	1	0	0	0	0	1	0	1	85H
\$50 Credit	1	0	0	0	0	1	1	0	86H
\$100 Credit	1	0	0	0	0	1	1	1	87H
Reserved	1	0	0	0	1	0	0	0	88H
Vend	1	0	0	0	1	0	0	1	89H
Return	1	0	0	0	1	0	1	0	8AH
Reject	1	0	0	0	1	0	1	1	8BH
Failure	1	0	0	0	1	1	0	0	8CH
Full or Jam	1	0	0	0	1	1	0	1	8DH

Low Level Credit Line Mode- \$1 and \$5 Model Only

This mode of operation is compatible with the Mars VFM3 low level interface that uses \$1, \$5 enable lines and escrow lines. The primary difference is that there is no \$2 enable on the XLC bill acceptor, since it does not accept that bill.

Note: This interface is only available on the \$1, \$5 only 5200 Model of the XLC bill acceptor.

Note: To enable this mode on the acceptor, make sure the Configuration Card has been configured for “\$1/\$5 Credit Lines” mode.

In this mode, you use \$1 and \$5 high enable and low enable lines to enable a bill. The output of the bill acceptor is either the relay contacts (if an optional 120 VAC power supply is used) or the \$1 or \$5 credit lines (see below for details).

Low Level Credit Line Mode- \$1-\$5 Model only - Inputs and Outputs

Power

120 VAC Model- Connect 120 VAC power to Pins 4 (Black wire) and 6 (White wire) on the 9-pin connector (see Figure 2).

12 VDC Model- Connect +12 VDC to Pin 11 (Red wire) on the 18-pin connector (see Figure 2) Connect DC Ground to Pin 4 (Black wire) on the 18-pin connector.

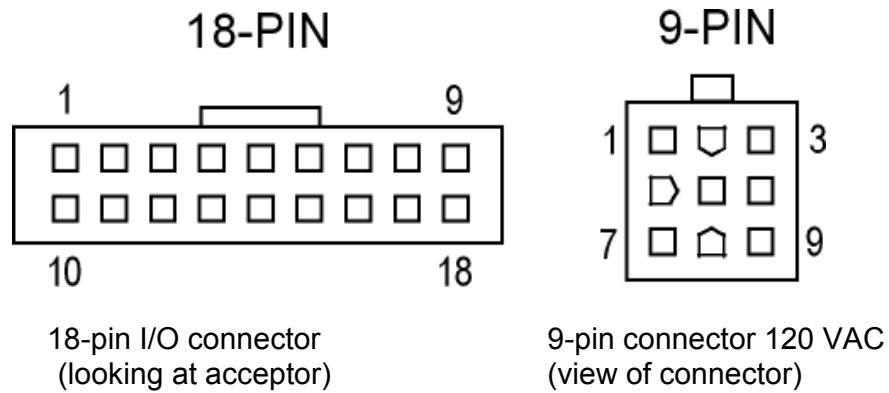

Figure 2

18-pin Mating Connector

- Amp “Modu” 18-pin, P/N 102398-7 (IDC Housing)
- Amp Back Cover P/N 102536-7
- Amp Front Cover P/N 102681-4

9-pin Mating Connector

- Amp Mate-N-Lock 9-pin P/N 172161-1
- Amp Pin, Male P/N 170364-1

Low Level Credit Line Mode- \$1 and \$5 Model Only (Continued)- Inputs and Outputs

Pin Function and Location (See Figure 2 on page 22.)	Pin Description
\$1 Enable High- Pin 9 (White wire) on 18-pin connector. \$1 Enable Low- Pin 15 (White/Yellow wire) on 18-pin connector.	Tie the Enable High to +5V DC and the Enable Low to DC Ground to enable this bill (0-5V DC operation only).
\$5 Enable High- Pin 7 (Gray wire) on 18-pin connector \$5 Enable Low- Pin 17 (White/Green wire) on 18-pin connector.	Tie the Enable High to +5V DC and the Enable Low to DC Ground to enable this bill (0-5V DC operation only).
Escrow High Line- Pin 6 (Light Blue wire) on 18-pin connector. Escrow Low Line- Pin 18 (White/Gray wire) on 18-pin connector.	Use these lines to control the escrow feature on the bill acceptor (0-5V DC operation only).
DC Ground- Pin 4 (Black wire) on the 18-pin connector.	DC ground
\$1 Credit Output- Pin 1 (Brown wire) on the 18-pin connector.	Normally high, open-collector Credit Line. Pulled low when credit is issued. 150 msec pulse is sent when the credit is issued (5-12 VDC, 40 ma Max).
\$5 Credit Output- Pin 3 (Yellow wire) on the 18-pin connector.	Normally high, open-collector Credit Line. Pulled low when credit is issued. 150 msec pulse is sent when the credit is issued (5-12 VDC, 40 mA Max).
Relay Credit Output (120 VAC model only)- Pin 7 (Brown wire) and Pin 8 (Blue wire) of the 9-pin connector.	Relay output rated 1 Amp at 120 VAC. Relay will close and open a number of times based on the Pulses Per Dollar configuration set with the Configuration Card. Based on how you configured the acceptor, the acceptor will put out a 50 msec on/50 msec off pulse, or a 50 msec on/300 msec off pulse. Due to relay contact bounce, it is recommended that the software engineer incorporate a 10 msec software delay to debounce the relay contacts.

In addition, both the 120 VAC model and 12 VDC model have an “Out of Service” output located on Pin 10 (Tan wire) of the 18-pin connector. It is a normally high, open-collector output transistor that is pulled low when the acceptor is Out of Service. (5-12 VDC at 40 ma Max.) Pin 13 (White/Orange wire) of the 18-pin connector has a 330 ohm resistor tied to +5VDC to power an LED.

Always Enabled Mode of Operation

This mode of operation is the simplest to understand. In this mode, the acceptor is always enabled. It will accept all valid bills that are programmed to be accepted by the Configuration Card. Note: to enable this mode on the acceptor, make sure the Configuration Card has been configured for “Always Enabled” mode. The output of the bill acceptor is either the relay contacts (if a 120 VAC optional supply is used), or the Low Level Non-Isolated Credit Line (see below for details).

Always Enabled Mode- Outputs

Power

120 VAC Model- Connect 120 VAC power to Pins 4 (Black wire) and 6 (White wire) on the 9-pin connector (see Figure 4).

12 VDC Model- Connect +12 VDC to Pin 11 (Red wire) on the 18-pin connector (see Figure 4). Connect DC Ground to Pin 4 (Black wire) on the 18-pin connector.

In addition, both the 120 VAC model and 12 VDC model have an “Out of Service” output located on Pin 10 (Tan wire) of the 18-pin connector. It is a normally high, open-collector output transistor that is pulled low when the acceptor is Out of Service. (5-12 VDC at 40 ma Max.) Pin 13 (White/Orange wire) of the 18-pin connector has a 330 ohm resistor tied to +5VDC to power an LED.

Outputs

120 VAC Model- You can use the relay output on Pin 7 (Brown) and Pin 8 (Blue) of the 9-pin connector, or you can use the normally high, open-collector output transistor on Pin 1 (Brown wire) on the 18-pin connector. (5-12 VDC at 40 mA Max.)

12 VDC Model- Use the normally high, open-collector output transistor on Pin 1 (Brown wire) on the 18-pin connector (5-12 VDC at 40 mA max.)

All outputs will send the number of pulses and pulse speed as set by the Configuration Card.

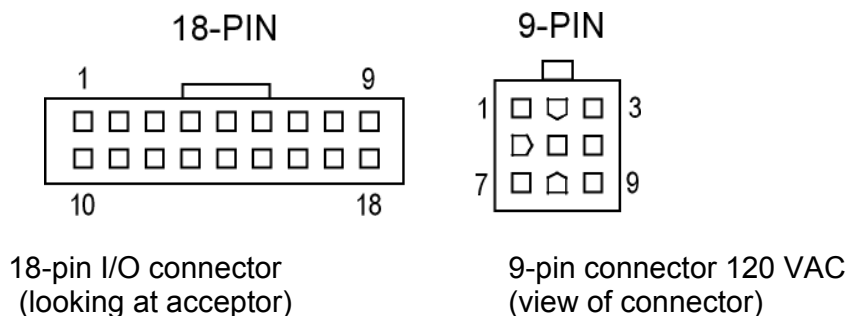

Figure 4

18-pin Mating Connector

Amp “Modu” 18-pin, P/N 102398-7 (IDC Housing)
 Amp Back Cover P/N 102536-7
 Amp Front Cover P/N 102681-4

9-pin Mating Connector

Amp Mate-N-Lock 9-pin P/N 172161-1
 Amp Pin, Male P/N 170364-1

RS-232 Mode (True RS-232 and TTL RS-232)

Note: To enable this mode on the acceptor, make sure the Configuration Card has been configured for “RS-232” mode.

In this mode, the user has a choice of True RS-232 levels or TTL levels.

TTL (5 VDC) levels are available in both a 120 VAC version and a 12 VDC version of the XLC bill acceptor. Order our Acceptor I/O Harness, Generic (P/N 05AA0002). With this cable, you must manually connect the wires to your machine.

True RS-232 levels are available only in the 12 VDC Model of the XLC bill acceptor. In the 12 VDC version, the harness has a DB-9 connector and hard drive connector installed to ease customer installation. Order RS-232 Communication Harness (P/N 05AA0009) to have this ability.

This RS-232 mode uses a three wire interface. This interface uses a Transmit Line (TXD), a Receive Line (RXD) and DC ground (Gnd).

This RS-232 Interface is compatible with the interface used on Mars™ GL5™ style acceptors. It is a polled interface where the host machine is the Master and the bill acceptor is the Slave.

For RS-232 communication protocol details, see the “support” section of our website.

TTL RS-232 Mode Power and I/O Connections (refer to Figure 5, page 26 for Pinouts)

Pin Function & Location	XLC 12 VDC Version	XLC 120 VAC Version
DC Ground- Pin 4 (Black wire) on the 18-pin connector.	DC communication ground and DC power ground.	DC communication ground.
+12VDC- Pin 11 (Red wire) on the 18-pin connector.	12VDC acceptor power.	Do not use this pin for 120 VAC version!
120 VAC Hot- Pin 4 (Black wire) on the 9-pin connector.	Do not use this pin for 12 VDC version.	120VAC hot.
120 VAC Neutral- Pin 6 (White wire) on the 9-pin connector.	Do not use this pin for 12 VDC version.	120 VAC neutral.
TXD Line- Pin 5 (Green wire) on the 18-pin connector.	TXD- XLC Transmit Line. Connect to Receive line on your equipment.	TXD- XLC Transmit Line. Connect to Receive line on your equipment.
RXD Line- Pin 16 (White/Red wire) on the 18-pin connector.	RXD- XLC Receive Line. Connect to Transmit line on your equipment.	RXD- XLC Receive Line. Connect to Transmit line on your equipment.

RS-232 Mode(Continued) (True RS-232 and TTL RS-232)

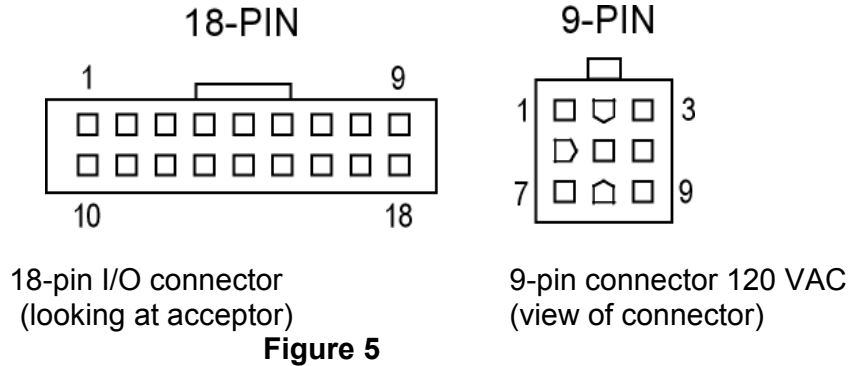

18-pin Mating Connector

Amp "Modu" 18-pin, P/N 102398-7 (IDC Housing)
 Amp Back Cover P/N 102536-7
 Amp Front Cover P/N 102681-4

9-pin Mating Connector

Amp Mate-N-Lock 9-pin P/N 172161-1
 Amp Pin, Male P/N 170364-1

True RS-232 Mode Power and I/O Connections

Pin Function and Location	XLC 12VDC Version
DC Ground- Pin 2 (Black wire) on the Hard Drive connector.	DC power ground.
+12VDC- Pin 1 (Yellow wire) on the Hard Drive connector.	12 VDC acceptor power.
Communication Ground- Pin 5 (Black wire) on the DB-9 connector.	DC communication ground.
TXD Line- Pin 3 (Green wire) on the DB-9 connector.	Connected to TXD line from your PC. (PC TXD line)
RXD Line- Pin 2 (White wire) on the DB-9 connector.	Connected to RXD line from your PC. (PC RXD line)

MDB Mode of Operation

Note: To enable this mode on the acceptor, make sure the Configuration Card has been configured for “MDB” mode.

MDB, or Multi-Drop Bus is a communication standard adopted by NAMA. In this configuration up to thirty-two (32) peripherals (or Slaves) can communicate to one Host (Master).

The Master initiates all communication to all devices on the bus.

6-PIN (MDB)

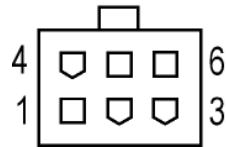

Figure 6 (view of connector)

Our MDB interface conforms to the MDB standard and uses the standard MDB connector (see Figure 6) for communication.

MDB Mode Power and I/O Connections (See Figure 6 for view of connector)

Pin Location	Pin Description
Pin 1	+34 VDC Power
Pin 2	DC power return
Pin 3	Not used
Pin 4	Master Receive
Pin 5	Master Transmit
Pin 6	Communications Common

Configuration Card

The Configuration Card is to be copied from the last page of this manual, using either a laser or a bubble jet copier. **Use standard photocopy paper.** After copying it, **make sure that it matches the original size of 6.0 x 2.6 inches (152 x 66 mm).**

Note: Copiers occasionally change the size of printed materials. This is why you should compare the copied card to the original card.

To use your copy, fill in the desired selections with **black felt-tipped ink** and cut the Configuration Card out along the solid line.

If you are printing this manual from a PDF file (which may be downloaded from our web site), **you must turn off any “shrink” or “expand” settings from within the print menu** to be sure the card is printed at the proper scale.



INSERT THIS SIDE UP, THIS END FIRST. USE BLACK FELT-TIPPED INK, FILL OVALS COMPLETELY



<input type="checkbox"/> Pulse/Serial	<input type="checkbox"/> \$1/\$5 Credit Lines	section 1 Select only one Interface Type
<input type="checkbox"/> MDB	<input type="checkbox"/> \$1-20 Credit Lines	
<input type="checkbox"/> RS-232	<input type="checkbox"/> Always Enabled	
<input type="checkbox"/> Parallel	<input type="checkbox"/> Hi	
<input type="checkbox"/> Special 1	<input type="checkbox"/> Special 2	

section 2

Pulses per Dollar (sum of selected values)

<input type="checkbox"/> 64	<input type="checkbox"/> 4
<input type="checkbox"/> 32	<input type="checkbox"/> 2
<input type="checkbox"/> 16	<input type="checkbox"/> 1
<input type="checkbox"/> 8	<input type="checkbox"/> None

Example:
For 50 ppd, fill in the ovals for 32, 16, and 2, (32+16+2 = 50)

Pulse Speed: Slow Fast

Lighted Bezel: Solid On Flashing

section 3

section 4

Select Bills to Enable

<input type="checkbox"/> Bill 1 (\$1)	<input type="checkbox"/> Bill 2 (\$5)
<input type="checkbox"/> Bill 3 (\$10)	<input type="checkbox"/> Bill 4 (\$20)
<input type="checkbox"/> Bill 5 (\$50)	<input type="checkbox"/> Bill 6 (\$100)
<input type="checkbox"/> Bill 7	<input type="checkbox"/> Bill 8
<input type="checkbox"/> Bill 9	<input type="checkbox"/> Bill 10
<input type="checkbox"/> Bill 11	<input type="checkbox"/> Bill 12

Example:
To accept USA \$1, \$5, and \$10, fill in the ovals for Bill 1, Bill 2, and Bill 3.

Security Level: High Low

Insert Direction: Face up, All 4 Ways
 Left 1st

section 5

This Configuration Card should be printed on standard copy paper, measuring 6.0 x 2.6 inches (152 x 66 mm).

If printing from a .PDF file, turn off the "shrink to fit" option in your printer settings for proper scale.



PYRAMID TECHNOLOGIES, INC.

CURRENCY VALIDATION EXPERTS

INSERT THIS SIDE UP, THIS END FIRST. USE BLACK FELT-TIPPED INK, FILL OVALS COMPLETELY



<input type="checkbox"/> Pulse/Serial	<input type="checkbox"/> \$1/\$5 Credit Lines	section 1 Select only one Interface Type
<input type="checkbox"/> MDB	<input type="checkbox"/> \$1-20 Credit Lines	
<input type="checkbox"/> RS-232	<input type="checkbox"/> Always Enabled	
<input type="checkbox"/> Parallel	<input type="checkbox"/> Hi	
<input type="checkbox"/> Special 1	<input type="checkbox"/> Special 2	

section 2

Pulses per Dollar (sum of selected values)

<input type="checkbox"/> 64	<input type="checkbox"/> 4
<input type="checkbox"/> 32	<input type="checkbox"/> 2
<input type="checkbox"/> 16	<input type="checkbox"/> 1
<input type="checkbox"/> 8	<input type="checkbox"/> None

Example:
For 50 ppd, fill in the ovals for 32, 16, and 2, (32+16+2 = 50)

Pulse Speed: Slow Fast

Lighted Bezel: Solid On Flashing

section 3

section 4

Select Bills to Enable

<input type="checkbox"/> Bill 1 (\$1)	<input type="checkbox"/> Bill 2 (\$5)
<input type="checkbox"/> Bill 3 (\$10)	<input type="checkbox"/> Bill 4 (\$20)
<input type="checkbox"/> Bill 5 (\$50)	<input type="checkbox"/> Bill 6 (\$100)
<input type="checkbox"/> Bill 7	<input type="checkbox"/> Bill 8
<input type="checkbox"/> Bill 9	<input type="checkbox"/> Bill 10
<input type="checkbox"/> Bill 11	<input type="checkbox"/> Bill 12

Example:
To accept USA \$1, \$5, and \$10, fill in the ovals for Bill 1, Bill 2, and Bill 3.

Security Level: High Low

Insert Direction: Face up, All 4 Ways
 Left 1st

section 5

This Configuration Card should be printed on standard copy paper, measuring 6.0 x 2.6 inches (152 x 66 mm).

If printing from a .PDF file, turn off the "shrink to fit" option in your printer settings for proper scale.



PYRAMID TECHNOLOGIES, INC.

CURRENCY VALIDATION EXPERTS

INSERT THIS SIDE UP, THIS END FIRST. USE BLACK FELT-TIPPED INK, FILL OVALS COMPLETELY



<input type="checkbox"/> Pulse/Serial	<input type="checkbox"/> \$1/\$5 Credit Lines	section 1 Select only one Interface Type
<input type="checkbox"/> MDB	<input type="checkbox"/> \$1-20 Credit Lines	
<input type="checkbox"/> RS-232	<input type="checkbox"/> Always Enabled	
<input type="checkbox"/> Parallel	<input type="checkbox"/> Hi	
<input type="checkbox"/> Special 1	<input type="checkbox"/> Special 2	

section 2

Pulses per Dollar (sum of selected values)

<input type="checkbox"/> 64	<input type="checkbox"/> 4
<input type="checkbox"/> 32	<input type="checkbox"/> 2
<input type="checkbox"/> 16	<input type="checkbox"/> 1
<input type="checkbox"/> 8	<input type="checkbox"/> None

Example:
For 50 ppd, fill in the ovals for 32, 16, and 2, (32+16+2 = 50)

Pulse Speed: Slow Fast

Lighted Bezel: Solid On Flashing

section 3

section 4

Select Bills to Enable

<input type="checkbox"/> Bill 1 (\$1)	<input type="checkbox"/> Bill 2 (\$5)
<input type="checkbox"/> Bill 3 (\$10)	<input type="checkbox"/> Bill 4 (\$20)
<input type="checkbox"/> Bill 5 (\$50)	<input type="checkbox"/> Bill 6 (\$100)
<input type="checkbox"/> Bill 7	<input type="checkbox"/> Bill 8
<input type="checkbox"/> Bill 9	<input type="checkbox"/> Bill 10
<input type="checkbox"/> Bill 11	<input type="checkbox"/> Bill 12

Example:
To accept USA \$1, \$5, and \$10, fill in the ovals for Bill 1, Bill 2, and Bill 3.

Security Level: High Low

Insert Direction: Face up, All 4 Ways
 Left 1st

section 5

This Configuration Card should be printed on standard copy paper, measuring 6.0 x 2.6 inches (152 x 66 mm).

If printing from a .PDF file, turn off the "shrink to fit" option in your printer settings for proper scale.



PYRAMID TECHNOLOGIES, INC.

CURRENCY VALIDATION EXPERTS